

# Welded Fittings

Catalog 4280  
Revised, February 2003



# Welded Fittings

## Introduction

In the chemical industry, process pressures are climbing higher and higher. The utility field, with its high steam pressures and hydraulic and pneumatic shutdown systems, demands the utmost in reliability. Nuclear power plants with their "hot" materials also have massive reliability problems. Such problem areas have given rise to the increased use of the permanent-weld-type tube fittings which provide a sturdy, tight integral line system that remains unaffected by shock, vibration or thermal distortion. The Parker Weld-lok® line of permanent socket weld tube fittings meets the most exacting requirements of any system.

## Heat Code Traceability

Parker Hannifin's Instrumentation Connectors Division offers Heat Code Traceability (HCT) on CPI™, A-LOK®, Instrumentation Pipe, Automatic Butt weld, and Weld-lok®.

HCT refers to the fact that a specific part can be traced back to the original mill heat of metal from which it was made. Beginning with the original melt, a package of documents is created which completely describes the metal in physical and chemical terms. The end result is that a number, which is permanently stamped to the part, refers back to the document package.

The HCT number is stamped on the material (bar stock or forging) prior to manufacturing. The concept is useful because it provides a method for complete material accountability for the manufacturer and end customer.

HCT offers these advantages:

- Raw materials for manufacture must meet code requirements. This can be verified through documentation so that the customer is certain that what is ordered is received.
- HCT provides a record of chemical analysis with the raw material. Thus, in areas requiring welding, the correct welding technique is applied.
- HCT relieves the user of Parker instrumentation tube fittings of any doubts. It acts as an assurance for today and for tomorrow.

The material used in Parker Hannifin instrumentation fitting components is 316 or 316L (welded products) stainless steel as specified and referenced in Section III of the ASME Boiler and Pressure Vessel code.

The American Society of Mechanical Engineers (ASME) Boiler and Vessel Code, Section III, latest issue, entitled Rules for Construction of Nuclear Power Plant Components, is the principal document covering this type of fitting in the nuclear field. ANSI Standard B.31.1, Power Piping, and ANSI Standard B.31.7, Nuclear Power Piping, are also important documents in the field.

In addition to the documentation of chemical and physical properties, great care is taken throughout the manufacture of Parker's tube fittings to ensure that potential stress corrosion will not be a problem in normal usage of the parts. Manufacturing processes avoid exposure of the parts to mercury or halogens, and control of thermal treatment avoids the condition known as continuous grain boundary carbide precipitation. (pg. 12)

**For additional information please contact your local authorized Parker Instrumentation distributor or call Parker Instrumentation Connectors Division and ask for Bulletin 4230-B15.**



### **WARNING**

FAILURE, IMPROPER SELECTION OR IMPROPER USE OF THE PRODUCTS AND/OR SYSTEMS DESCRIBED HEREIN OR RELATED ITEMS CAN CAUSE DEATH, PERSONAL INJURY AND PROPERTY DAMAGE.

This document and other information from Parker Hannifin Corporation, its subsidiaries and authorized distributors provide product and/or system options for further investigation by users having technical expertise. It is important that you analyze all aspects of your application and review the information concerning the product or system in the current product catalog. Due to the variety of operating conditions and applications for these products or systems, the user, through its own analysis and testing, is solely responsible for making the final selection of the products and systems and assuring that all performance, safety and warning requirements of the application are met.

The products described herein, including without limitation, product features, specifications, designs, availability and pricing, are subject to change by Parker Hannifin Corporation and its subsidiaries at any time without notice.

### **Offer of Sale**

The items described in this document are hereby offered for sale by Parker Hannifin Corporation, its subsidiaries or its authorized distributors. This offer and its acceptance are governed by the provisions stated in the "Offer of Sale".

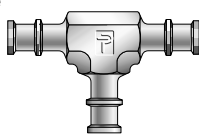
## Visual Index

### Automatic Butt weld Fittings

**Automatic Butt weld Union**  
YHY  
page 7



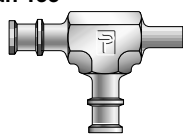
**Automatic Butt weld Union Tee**  
YJY  
page 7



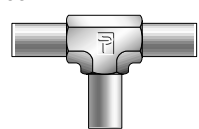
**Automatic Butt weld Manifold Branch Tee**  
YJT3  
page 7



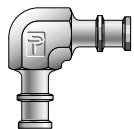
**Automatic Butt weld Manifold Run Tee**  
YJT3Y  
page 8



**Automatic Tube Butt weld Manifold Tee**  
T3JT3  
page 8



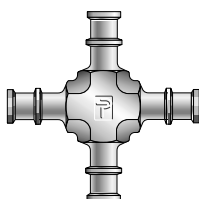
**Automatic Butt weld Union Elbow**  
YEY  
page 9



**Automatic Tube Butt weld Manifold Elbow**  
T3ET3  
page 9



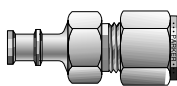
**Automatic Butt weld Cross**  
YKY  
page 10



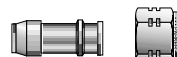
**Automatic Butt weld to CPI™ Tube Union**  
YHBZ  
page 10



**Automatic Butt weld to A-LOK® Tube Union**  
YHLZ  
page 10



**Automatic Butt weld Adapter to Compression Port Connector**  
ZPY & BY  
page 11



**Automatic Butt weld Plug**  
PNY  
page 11



### Weld-lok® Socket Weld Tube Fittings

**Union**  
HW  
page 14



**Tube Reducer**  
TRW  
page 14



**Elbow**  
EW  
page 14



**45° Elbow**  
NW  
page 15



**Tee**  
JW  
page 15




**Cross**  
KW  
page 15



**Male Elbow**  
CW  
page 16



**Male Connector**  
FW  
page 16




**Female Connector**  
GW  
page 16



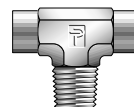
**Female Elbow**  
DW  
page 17



**Male Run Tee**  
RW  
page 17



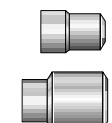
**Male Branch Tee**  
SW  
page 17



**Adapter**  
AW  
Page 18



**Adapter**  
AW2  
page 19

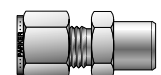


### Weld-lok® To Compression

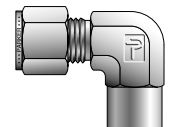
**Socket Weld Connector**  
ZHBW  
page 21



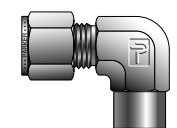
**Butt weld Connector**  
ZHBW2  
page 22



**Socket Weld Elbow**  
ZEBW  
page 23



**Butt weld Elbow**  
ZEBW2  
page 23



# Automatic Buttweld General Information

---

## Automatic Buttweld Purpose

Parker Buttweld fittings are designed for applications requiring the reliability of a welded tubing system. They were developed specifically for installation using automatic, orbital TIG (Tungsten/Inert Gas) welding equipment. These fittings offer the easiest, fastest and most reliable way to fabricate welded systems.

Automatic Buttweld fittings are available in 316, and 316L stainless steel in straight unions, tees, 90° elbows, and crosses. Automatic Buttweld ends are also available with male pipe and compression tube connections.

## Pressure

Pressure ratings will be governed by the tubing wall thickness selected for a particular application.

Working pressures are rated at room temperature based on a 4 to 1 design factor. Pressure ratings are calculated in accordance with ANSI Power Piping Code B31.1.

## Automatic Buttweld Principles of Operation

In an orbital welder, the electrode is contained and shielded within the head (see Figure 3). The head itself does not rotate; rather, the electrode rotates 360° within the head.

An orbital-type welder utilizes high-frequency current pulses, producing low-frequency arc pulses. These yield considerable arc penetration into the metal at low current values. As a result, arc-pressure variations are kept low and the resulting agitation of the weld puddle eliminates porosity and refines the grain structure at the weld area.

## To operate a TIG welding machine

1. Place the Automatic Buttweld fitting into the weld head, placing the locator rib in the corresponding locator groove.
2. Bottom the tubing (square cut, deburred) in the fitting end collar and close the second collet, which locks the tubing to the weld head. Engage the second collet.
3. Close the weld head. Press the "Start" button.

Note: Depending on the size and wall-thickness of the tubing, the welding machine parameters can be programmed to make one or more 360° passes. Once programmed, the machine will repeat the operation precisely, within very close tolerances and in areas too tight for manual welding.

---

## Backing Gas

Backing gas is an inert gas used to flood the interior of the fittings and tube system during welding. By reducing the interior oxygen level to as low as practicable, it also serves to control the combustion of contaminants that could affect weld quality.

When a backing gas is not used and nearly 100% weld penetration is achieved, blisters will tend to form on the internal tube wall. This will result in scale which may later break loose.

In most cases the backing gas will be argon or helium connected to the system through a control regulator. Flow rates,

## Automatic Centering of Electrode

Each Parker Automatic Buttweld fitting has an external locator rib (patented) situated a fixed distance from the end welding collar (see Figure 1). When the welder-head clamping collet is applied, the rib fits snugly within a corresponding annular groove in the collet.

As the electrode orbits, the collet follows the rib, maintaining precise positioning of the electrode, over the end collar (see Figure 2). Thus, electrode and welding positioning are always accurately aligned.

## End Weld Collar

On the O.D. of each Automatic Buttweld fitting end, there is an end collar. During welding, the electrode tip is positioned directly over this end collar. As the electrode orbits, a uniform bead on the butt-seam is achieved.

## Piloted Mating of Tube to Fitting

The end collar of the Automatic Buttweld fitting is counter bored. This serves as a pilot for the tube end, guiding it accurately into the fitting end.

This feature provides for accurate alignment and consistent welds every time.

## Compensation for Tube-Thickness Variations

The outside diameter of the end collar is designed to compensate for normal variations in the nominal O.D. of instrumentation tubing.

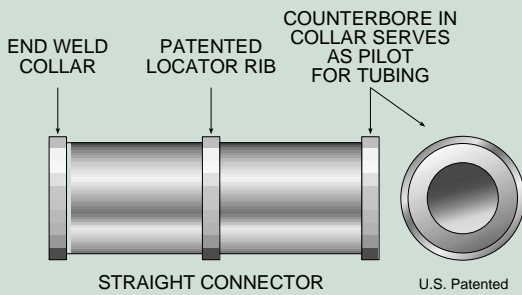
In addition, each fitting is machined for the specific wall thickness being specified.

These two features allow for the fitting bore and tube I.D. to be carefully matched. Thus, an ABW connection will allow for full flow, with no protrusions extending into the flow path. This will reduce a major cause of turbulence.

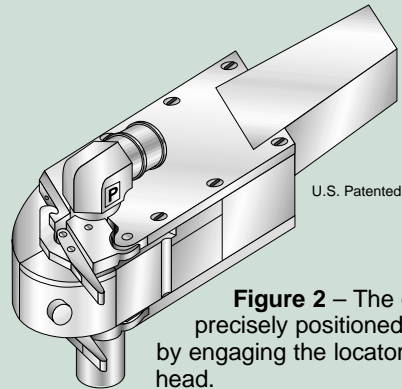
while small, should be high enough to purge the system. Welds should be made in downstream sequence from the gas connection.

Note that the entire system should be purged to insure that there are no openings that will allow air to be drawn into the system.

The use of backing gas, while often not mandatory, will give a better weld joint. This is because the welds are made and cooled under a shielded atmosphere, thus eliminating internal scaling or blistering.

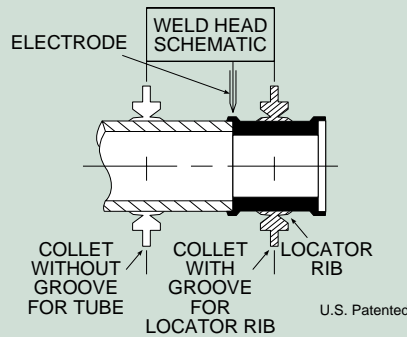


**Figure 1** – The Automatic Buttweld fitting has a locator rib positioned a fixed distance from the end weld collar.



**Figure 2** – The orbiting electrode is precisely positioned over the end collar by engaging the locator rib within the weld head.

**Note:** The weld head shown is for illustration only.



**Figure 3** – The orbital welder electrode is shielded within the stationary head and rotates 360° to produce uniform, accurate welds.

## Materials

**Automatic Buttweld Tube Fittings** are available in stainless steel (Type 316 and 316L - AOD/VAR and 316L VIM/VAR). Straight fittings are machined from cold finished bar stock and shaped bodies are machined from close grain forgings. The raw materials used for fittings fully conform to the chemical and mechanical requirements of one or more of the specifications listed in the table on page 6. For nuclear and other critical applications, Automatic Buttweld fittings are available with documented heat code traceability. (See page 2)

# How to Order Automatic Butt weld

## Nomenclature

Parker Automatic Butt weld Tube Fittings part numbers are constructed from symbols that identify the size and configuration of the fittings and material used.

## How To Order

Parker Butt weld components are ordered by part number as listed in this catalog.

**Example:** If your system requires an elbow fitting going from 1/4" tubing to 1/4" tubing, .035 wall thickness, you would order the following part:

**4-4 YEY-SS .035** (Automatic Butt weld)

**Fitting Size** – The first two numbers denote the fitting size which matches the tubing O.D.

**Machining Type** – First end ABW only (Y).

**Fitting Type** – Straight (H), Union tee (J), Union elbow (E).

**Machining Type** – Second end, ABW (Y), Male pipe (F), CPI™/A-LOK® end assembled (BZ/LZ).

**Wall Thickness** – Fittings must be specified to match the corresponding tube wall thickness. Standard wall thicknesses:  
 Size 4 and 6 – .035 wall thickness  
 Size 8 – .049 wall thickness  
 Other wall thicknesses available upon request.

**Material** – Stainless Steel - SS (316L)  
 AOD/VAR - SSR (316R)  
 VIM/VAR - SSV (316V)

**Size:** Tube and pipe thread sizes are designated by the number of sixteenths of an inch (1/4" tube = 4/16" = size 4), (3/8" tube = 6/16" = size 6), and (1/2" tube = 8/16" = size 8).

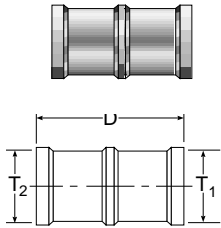
**Special fittings:** If a special fitting configuration is required, it is suggested that a sketch or drawing be submitted for review.

**Availability:** Only items listed in current price list are carried in stock. Customer Specials may be quoted through Parker ICD Division Customer Service.

| TYPICAL RAW MATERIAL SPECIFICATIONS |  |                        |   |
|-------------------------------------|--|------------------------|---|
| FITTING MATERIAL                    | BAR STOCK  | FORGINGS               | RECOMMENDED TUBING SPECIFICATIONS   |
| Stainless Steel 316L                | ASTM A-276 TYPE 316LSS<br>ASME SA-479 TYPE 316L-SS | ASME SA-182 GRADE 316L | ASME SA-213<br>ASTM A-213<br>ASTM A-249<br>ASTM A-269<br>MIL T-8504<br>MIL T-8506 |
| Stainless Steel 316L (AOD/VAR)      |  |                        |   |
| Stainless Steel 316L (VIM/VAR)      |  |                        |   |

# Automatic Butt weld Fittings

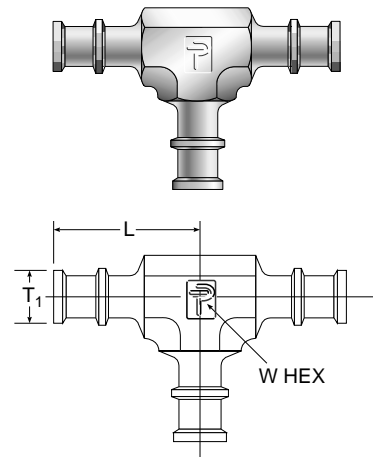
## Automatic Butt weld Union YHY



| PART NO.  | INCHES |                |                |                           |
|-----------|--------|----------------|----------------|---------------------------|
|           | D      | T <sub>1</sub> | T <sub>2</sub> | *AUTO-BUTT WELD WALL SIZE |
| 4-4 YHY   | 0.77   | 1/4            | 1/4            | .035-.035                 |
| 6-4 YHY   | 1.34   | 3/8            | 1/4            | .035-.035                 |
| 6-6 YHY   | 0.77   | 3/8            | 3/8            | .035-.035                 |
| 8-4 YHY   | 1.48   | 1/2            | 1/4            | .049-.035                 |
| 8-6 YHY   | 1.48   | 1/2            | 3/8            | .049-.035                 |
| 8-8 YHY   | 0.77   | 1/2            | 1/2            | .049-.049                 |
| 12-12 YHY | 1.07   | 3/4            | 3/4            | .065-.065                 |
| 16-16 YHY | 1.07   | 1              | 1              | .095-.095                 |

\*Other fittings and wall sizes available upon request

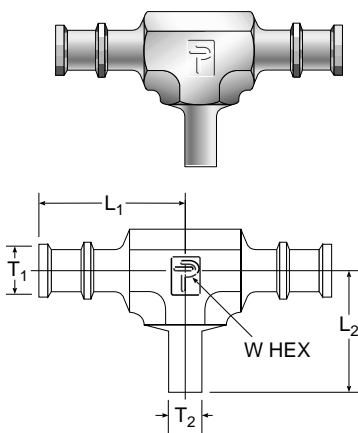
## Automatic Butt weld Union Tee YJY



| PART NO.     | INCHES |                |                           |        |
|--------------|--------|----------------|---------------------------|--------|
|              | L      | T <sub>1</sub> | *AUTO-BUTT WELD WALL SIZE | W HEX  |
| 4-4-4 YJY    | 1.06   | 1/4            | .035                      | 7/16   |
| 6-6-6 YJY    | 1.19   | 3/8            | .035                      | 9/16   |
| 8-8-8 YJY    | 1.44   | 1/2            | .049                      | 3/4    |
| 12-12-12 YJY | 1.64   | 3/4            | .065                      | 1-1/16 |
| 16-16-16 YJY | 1.81   | 1              | .095                      | 1-5/16 |

\*Other fittings and wall sizes available upon request

## Automatic Butt weld Manifold Branch Tee YJT3



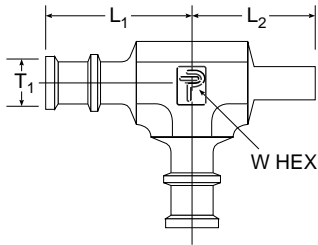
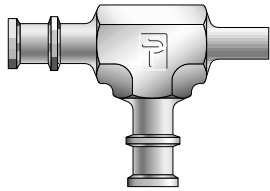
| PART NO.   | INCHES         |                |                |                |                           | W HEX |
|------------|----------------|----------------|----------------|----------------|---------------------------|-------|
|            | L <sub>1</sub> | L <sub>2</sub> | T <sub>1</sub> | T <sub>2</sub> | *AUTO-BUTT WELD WALL SIZE |       |
| 4-4-4 YJT3 | 1.06           | 1.03           | 1/4            | 1/4            | .035                      | 7/16  |
| 6-6-4 YJT3 | 1.19           | 1.15           | 3/8            | 1/4            | .035                      | 9/16  |

\*Other fittings and wall sizes available upon request

Dimensions for reference only, subject to change.

# Automatic Butt weld Fittings

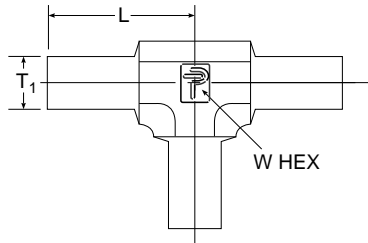
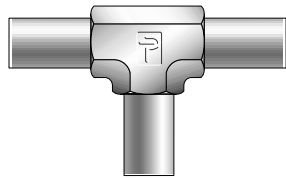
## Automatic Butt weld Manifold Run Tee YJT3Y



| PART NO.    | INCHES         |                |                |                          |       |
|-------------|----------------|----------------|----------------|--------------------------|-------|
|             | L <sub>1</sub> | L <sub>2</sub> | T <sub>1</sub> | *AUTO-BUTTWELD WALL SIZE | W HEX |
| 4-4-4 YJT3Y | 1.06           | 1.03           | 1/4            | .035                     | 7/16  |

\*Other fittings and wall sizes available upon request

## Automatic Tube Butt weld Manifold Tee T3JT3

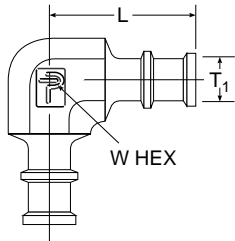
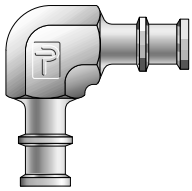


| PART NO.    | INCHES |                |       |
|-------------|--------|----------------|-------|
|             | L      | T <sub>1</sub> | W HEX |
| 4-4-4 T3JT3 | 1.03   | 1/4            | 7/16  |

Dimensions for reference only, subject to change.

# Automatic Butt weld Fittings

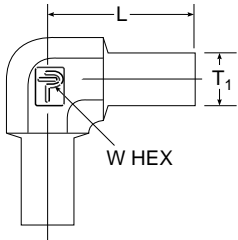
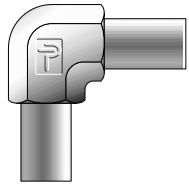
## Automatic Butt weld Union Elbow YEY



| PART NO.  | INCHES |                |                          |        |
|-----------|--------|----------------|--------------------------|--------|
|           | L      | T <sub>1</sub> | *AUTO-BUTTWELD WALL SIZE | W HEX  |
| 4-4 YEY   | 1.06   | 1/4            | .035                     | 7/16   |
| 6-6 YEY   | 1.19   | 3/8            | .035                     | 9/16   |
| 8-8 YEY   | 1.44   | 1/2            | .049                     | 3/4    |
| 12-12 YEY | 1.64   | 3/4            | .065                     | 1-1/16 |
| 16-16 YEY | 1.81   | 1              | .095                     | 1-5/16 |

\*Other fittings and wall sizes available upon request

## Automatic Tube Butt weld Manifold Elbow T3ET3

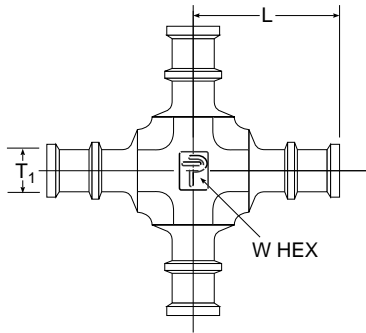
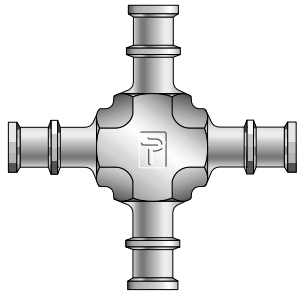


| PART NO.  | INCHES |                |       |
|-----------|--------|----------------|-------|
|           | L      | T <sub>1</sub> | W HEX |
| 4-4 T3ET3 | 1.03   | 1/4            | 7/16  |

Dimensions for reference only, subject to change.

# Automatic Butt weld Fittings

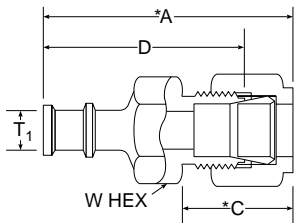
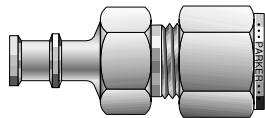
## Automatic Butt weld Cross YKY



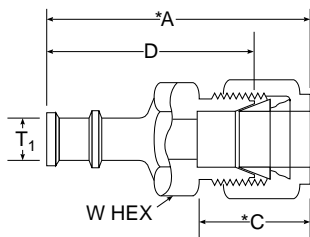
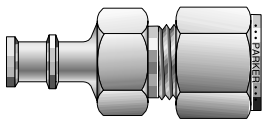
| PART NO. | INCHES |                |                           |       |
|----------|--------|----------------|---------------------------|-------|
|          | L      | T <sub>1</sub> | *AUTO-BUTT WELD WALL SIZE | W HEX |
| 4 YKY    | 1.06   | 1/4            | .035                      | 7/16  |
| 6 YKY    | 1.19   | 3/8            | .035                      | 9/16  |
| 8 YKY    | 1.44   | 1/2            | .049                      | 3/4   |

\*Other fittings and wall sizes available upon request

## Automatic Butt weld to Tube Union



CPI™



A-LOK®

| PART NO. (CPI™) | INCHES |                |      |     |                            |       |
|-----------------|--------|----------------|------|-----|----------------------------|-------|
|                 | D      | T <sub>1</sub> | *A   | *C  | **AUTO-BUTT WELD WALL SIZE | W HEX |
| 4-4 YHBZ        | 1.42   | 1/4            | 1.71 | .70 | .035                       | 1/2   |
| 6-6 YHBZ        | 1.51   | 3/8            | 1.80 | .78 | .035                       | 5/8   |
| 8-8 YHBZ        | 1.71   | 1/2            | 2.11 | .91 | .049                       | 13/16 |

Silver plated nut and single ferrule are provided as shown.

\*Dimensions shown with nut finger tight

\*\*Other fittings and wall sizes available upon request.

| PART NO. (A-LOK®) | INCHES |                |      |     |                            |       |
|-------------------|--------|----------------|------|-----|----------------------------|-------|
|                   | D      | T <sub>1</sub> | *A   | *C  | **AUTO-BUTT WELD WALL SIZE | W HEX |
| 4-4 YHLZ          | 1.42   | 1/4            | 1.71 | .70 | .035                       | 1/2   |
| 6-6 YHLZ          | 1.51   | 3/8            | 1.80 | .76 | .035                       | 5/8   |
| 8-8 YHLZ          | 1.71   | 1/2            | 2.11 | .87 | .049                       | 13/16 |

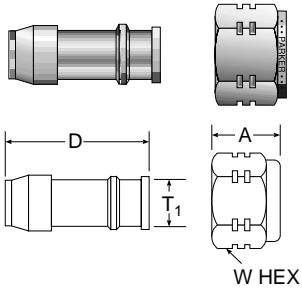
Silver plated nut and ferrules are provided as shown.

\*Dimensions shown with nut finger tight

\*\*Other fittings and wall sizes available upon request.

Dimensions for reference only, subject to change.

## Automatic Butt weld Adapter to Compression Port Connector ZPY

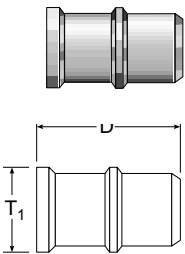


| BODY PART NO. | INCHES |                |                           |
|---------------|--------|----------------|---------------------------|
|               | D      | T <sub>1</sub> | *AUTO-BUTT WELD WALL SIZE |
| 4-4 ZPY       | 1.12   | 1/4            | .035                      |
| 6-6 ZPY       | 1.09   | 3/8            | .035                      |
| 8-8 ZPY       | 1.52   | 1/2            | .049                      |
| 12-12 ZPY     | 1.50   | 3/4            | .049                      |
| 16-16 ZPY     | 1.71   | 1              | .083                      |

| NUT PART NO. | INCHES |       |
|--------------|--------|-------|
|              | A      | W HEX |
| 4 BY         | .50    | 9/16  |
| 6 BY         | .56    | 11/16 |
| 8 BY         | .69    | 7/8   |
| 12 BY        | .69    | 1-1/8 |
| 16 BY        | .81    | 1-1/2 |

\*Other fittings and wall sizes available upon request

## Automatic Butt weld Plug PNY



| PART NO. | INCHES |                |                           |
|----------|--------|----------------|---------------------------|
|          | D      | T <sub>1</sub> | *AUTO-BUTT WELD WALL SIZE |
| 4 PNY    | 0.72   | 1/4            | .035                      |
| 6 PNY    | 0.72   | 3/8            | .035                      |
| 8 PNY    | 0.72   | 1/2            | .049                      |
| 12 PNY   | 1.02   | 3/4            | .065                      |
| 16 PNY   | 1.02   | 1              | .095                      |

\*Other fittings and wall sizes available upon request

Dimensions for reference only, subject to change.

## Weld-lok® Socket Weld Fittings

The weld used in joining a tube to a socket weld tube fitting is like any other type of “tee” weld. The root (i.e., the point of intersection of the outside of the tube and annular end area of the fitting) must be included in the weld zone.

Careful welding procedures are normally followed to assure that this root area is included in the weld. If penetration is not achieved, the joint will have two built-in stress risers which may greatly reduce the strength of the weld. Upon application of an extreme load, these stress risers could result in cracks which could propagate out through the weld or tube depending upon the direction of the greatest load.

Often to achieve full root penetration in TIG welding of stainless steels, a fusion pass will be made first, followed by a final pass utilizing a filler rod to achieve the desired fillet size.

## Assembly

The codes applicable to the welding of socket weld fittings require that the tube be inserted into the socket until bottomed against the stop. The tube is then to be backed out approximately 1/16 of an inch and then welded.

If the tube is not backed out, but welded when against a flat bottom stop, the contraction of the weld fillet and fitting socket can combine to produce a static stress on the weld. During thermal transients, the fitting and the portion of the tube within the fitting may experience a differential rate of heating or cooling, again adding to the stress level in the weld.

## Tacking

If the weld joint is to be “tacked” before welding, it is recommended that the “Tack” weld build-up be held to a minimum.

Excessive build-up on the “tack” may cause an interrupted final bead and a stress riser or lack of complete fusion.

## Backing Gas

Backing gas is an inert (no active properties) gas used to flood the interior of the fittings and tube system during welding. It serves the same purpose internally as the shielding gas used in TIG or MIG welding. By reducing the interior oxygen level to as low as practicable, it also serves to control the combustion of contaminants that could affect weld quality.

When a backing gas is not used and nearly 100% weld penetration is achieved, blisters will tend to form on the internal tube wall. This will result in scale which may later break loose. Therefore, in 0.050 wall or thinner tube or where the wall thickness is such that the selected weld process may burn through, the use of a backing gas is required.

In most cases the backing gas will be argon or helium connected to the system through a control regulator. Flow rates, while small, should be high enough to purge the system. Welds should be made in downstream sequence from the gas connection.

Note that the entire system should be purged to insure that there are no openings that will allow air to be drawn into the system.

The use of backing gas, while often not mandatory, will give a better weld joint. This is because the effects of contaminate combustion by-products are eliminated and because the welds are made and cooled under a shielded atmosphere, thus eliminating internal scaling or blistering.

## Welding Methods

### Arc Polarity

When welding Weld-lok® fittings, best results will be obtained by the following arc polarities:

TIG – Direct Current, straight polarity  
MIG – Direct Current, reverse polarity  
STICK – Polarity dependent on rod used.

### 300 Series Stainless Steels

May be welded by the TIG, MIG, or stick arc-weld process.

TIG welding is recommended as being best for welding Weld-lok® systems because it allows better operator control of heat penetration and filler material deposition.

Stick arc welding is not recommended in many cases because of the likelihood of excessive burn-through and improper root penetration. In all cases where stick welding is used, it is recommended that backing gas be used.

MIG welding gives the same characteristics as stick electrode welding with faster deposition of the filler material. As this process runs “hotter” than the stick process, the use of a backing gas is mandatory. It should be noted that in welding the relatively small fitting sizes found in the Weld-lok® line, filler deposition rate economies are not a factor and therefore the MIG method is not commonly applied.

### C1018 Steel Fittings

May be welded by the TIG, MIG, stick and oxyacetylene methods. As scale formation remains a problem, the use of a backing gas is still recommended.

### Carbide Precipitation

When unstabilized stainless steels are heated to 800°–1500°F during welding, the chromium in the steel combines with the carbon to form chrome carbides which tend to form along the grain boundaries of the metal (carbide precipitation). This lowers the dissolved chromium content in these areas and thus lowers their corrosion resistance, making them vulnerable to intergranular corrosion. Carbide precipitation is reduced by holding the carbon content of the material to a very low value. This limits the amount of carbon available to combine with the chromium. The “L” series (extra low carbon) stainless steels are often used for this purpose, but their use reduces system design stress by approximately 15%. Parker Weld-lok® fittings are made from a select 316 series with carbon content in the low range of 0.04 to 0.07 percent. This results in a welded fitting with good corrosion resistance and a high strength factor.

All Parker Weld-lok® fittings in stainless steel are supplied in the solution-treated condition, capable of passing ASTM-A-262 Tests for Detecting Susceptibility to Intergranular Corrosion.

## How To Order

Parker Weld-lok® components are ordered by part number as listed in this catalog.

**Example:** If your system requires a 90° elbow fitting going from 1/4" tubing to 1/4" tubing, you would order the following part:

**4-4 EW-SS**

**Fitting Size** – The first two numbers denote the fitting size which matches the tubing O.D.

**Material** – Stainless Steel - SS (316L)

**Welded Fitting Type** – Straight (H), Union tee (J), Union elbow (E).

**Machining Type** – Weld-lok® (W)

**Size:** Tube and pipe thread sizes are designated by the number of sixteenths of an inch (1/4" tube = 4/16" = size 4), (3/8" tube = 6/16" = 6), and (1/2" tube = 8/16" = size 8).

**Special fittings:** If a special fitting configuration is required, it is suggested that a sketch or drawing be submitted for review.

**Availability:** Only items listed in current price list (4280) are carried in stock. Customer Specials may be quoted through the Parker ICD Quick Response Department.

| TYPICAL RAW MATERIAL SPECIFICATIONS |  |                        |   |
|-------------------------------------|--|------------------------|---|
| FITTING MATERIAL                    | BAR STOCK  | FORGINGS               | RECOMMENDED TUBING SPECIFICATIONS   |
| Stainless Steel 316L                | ASTM A-276 TYPE 316LSS<br>ASME SA-479 TYPE 316L-SS | ASME SA-182 GRADE 316L | ASME SA-213<br>ASTM A-213<br>ASTM A-249<br>ASTM A-269<br>MIL T-8504<br>MIL T-8506 |
| Stainless Steel 304                 | TBA  | TBA                    |   |

## Where To Order

Parker Weld-lok® components are ordered with the Instrumentation Connectors Division.  
P.O. Box 400004-1504  
Huntsville, AL 35815-1504  
Phone: 256-881-2040

## Design Specifications

The Weld-lok® fitting has been designed and tested in accordance with ANSI B16.11, which covers "Forged Steel Fittings Socket Welded and Threaded." Our design parallels the Schedule 80, 3000-pound fitting pressure class, and is compatible with O.D. tube wall thickness meeting the related (3000-psi pipe class) pressure requirements. Strong, full section forgings are used for all "shape" fittings.

## User Specification Requirements

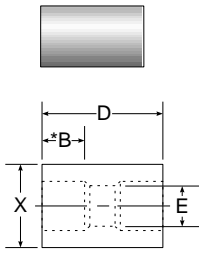
The 316 stainless steel Weld-lok® fittings fully conforms to the applicable specifications covered in:

- ANSI B31.1 "Power Piping"
  - ANSI B31.7 "Nuclear Power Piping"
  - Section III, "Nuclear Power Plant Component," ASME Boiler and Pressure Vessel Code
- Customer Specials may be quoted through the Parker Quick Response Department.

# Weld-lok® Socket Weld Tube Fittings

## Union

HW • tube socket end – both ports

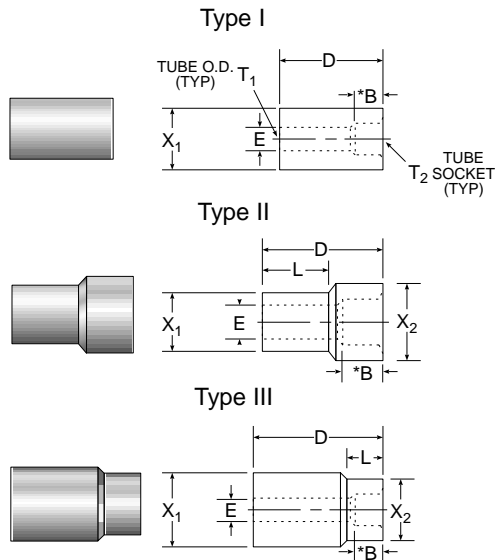


| PART NO. | TUBE O.D. | TUBE O.D. | E SMALL BORE | *B      | D     | J       | X DIA.    | WORK. PRES. |
|----------|-----------|-----------|--------------|---------|-------|---------|-----------|-------------|
| 2 HW     | 1/8       | 1/8       | .09          | .156    | .69   |         | .375      | 10,200      |
| 3 HW     | 3/16      | 3/16      | .14          | .203    | .78   |         | .438      | 9,600       |
| 4-3 HW   | 1/4       | 3/16      | .14          | .25-.20 | .85   | .44-.39 | .50-.44   | 9,600       |
| 4 HW     | 1/4       | 1/4       | .19          | .250    | .88   |         | .500      | 9,600       |
| 5 HW     | 5/16      | 5/16      | .25          | .313    | 1.00  |         | .594      | 9,900       |
| 6-4 HW   | 3/8       | 1/4       | .19          | .34-.25 | 1.00  | .53-.44 | .63-.50   | 8,100       |
| 6 HW     | 3/8       | 3/8       | .31          | .344    | 1.06  |         | .625      | 8,100       |
| 8-4 HW   | 1/2       | 1/4       | .19          | .41-.25 | 1.11  | .59-.44 | .78-.50   | 7,300       |
| 8-6 HW   | 1/2       | 3/8       | .31          | .41-.34 | 1.17  | .59-.53 | .78-.63   | 7,300       |
| 8 HW     | 1/2       | 1/2       | .44          | .406    | 1.19  |         | .781      | 7,300       |
| 10-6 HW  | 5/8       | 3/8       | .31          | .47-.34 | 1.28  | .66-.53 | .94-.63   | 6,600       |
| 10 HW    | 5/8       | 5/8       | .50          | .469    | 1.31  |         | .938      | 6,600       |
| 12-4 HW  | 3/4       | 1/4       | .19          | .50-.25 | 1.30  | .69-.44 | 1.09-.50  | 6,000       |
| 12-8 HW  | 3/4       | 1/2       | .44          | .50-.41 | 1.37  | .69-.59 | 1.09-.78  | 6,000       |
| 12-10 HW | 3/4       | 5/8       | .50          | .50-.47 | 1.39  | .69-.66 | 1.09-.94  | 6,000       |
| 12 HW    | 3/4       | 3/4       | .66          | .500    | 1.38  |         | 1.094     | 6,000       |
| 14 HW    | 7/8       | 7/8       | .78          | .500    | 1.38  |         | 1.312     | 5,700       |
| 16-8 HW  | 1         | 1/2       | .44          | .56-.41 | 1.53  | .75-.59 | 1.44-.78  | 4,900       |
| 16-12 HW | 1         | 3/4       | .66          | .56-.50 | 1.54  | .75-.69 | 1.44-1.09 | 4,900       |
| 16 HW    | 1         | 1         | .91          | .563    | 1.50  |         | 1.44      | 4,900       |
| 20-12 HW | 1-1/4     | 3/4       | .66          | .63-.50 | 1.69  | .81-.69 | 1.75-1.09 | 4,600       |
| 20-16 HW | 1-1/4     | 1         | .91          | .63-.56 | 1.65  | .81-.75 | 1.75-1.44 | 4,600       |
| 20 HW    | 1-1/4     | 1-1/4     | 1.06         | .625    | 1.625 |         | 1.750     | 4,600       |
| 24-8 HW  | 1-1/2     | 1/2       | .44          | .67-.41 | 1.80  | .86-.59 | 2.0-.78   | 3,700       |
| 24-16 HW | 1-1/2     | 1         | .91          | .67-.56 | 1.77  | .86-.75 | 2.0-1.44  | 3,700       |
| 24-20 HW | 1-1/2     | 1-1/4     | 1.06         | .67-.63 | 1.74  | .86-.81 | 2.0-1.75  | 3,700       |
| 24 HW    | 1-1/2     | 1-1/2     | 1.31         | .670    | 1.84  |         | 2.0       | 3,700       |
| 32-16 HW | 2         | 1         | .91          | .78-.56 | 2.06  | .97-.75 | 2.62-1.44 | 3,300       |
| 32 HW    | 2         | 2         | 1.81         | .781    | 2.13  |         | 2.625     | 3,300       |

\*Socket Depth

## Tube Reducer

TRW • tube socket reducer



| PART NO.  | T <sub>1</sub> SIZE | T <sub>2</sub> TUBE SOCK. | TYPE | D    | X <sub>1</sub> DIA. | X <sub>2</sub> DIA. | L   | E SMALL BORE | *B   | WORK. PRES. |
|-----------|---------------------|---------------------------|------|------|---------------------|---------------------|-----|--------------|------|-------------|
| 6-4 TRW   | 3/8                 | 1/4                       | II   | .94  | .375                | .500                | .47 | .19          | .250 | 9,600       |
| 8-4 TRW   | 1/2                 | 1/4                       | I    | .88  | .500                | .50                 | -   | .19          | .250 | 9,600       |
| 8-6 TRW   | 1/2                 | 3/8                       | II   | 1.13 | .500                | .63                 | .56 | .31          | .344 | 7,800       |
| 10-4 TRW  | 5/8                 | 1/4                       | III  | 1.22 | .623                | .50                 | .44 | .19          | .250 | 9,600       |
| 10-6 TRW  | 5/8                 | 3/8                       | I    | 1.03 | .623                | .62                 | -   | .31          | .344 | 8,100       |
| 10-8 TRW  | 5/8                 | 1/2                       | II   | 1.26 | .623                | .78                 | .63 | .41          | .406 | 6,100       |
| 12-4 TRW  | 3/4                 | 1/4                       | III  | 1.32 | .750                | .50                 | .44 | .19          | .250 | 9,600       |
| 12-6 TRW  | 3/4                 | 3/8                       | III  | 1.38 | .750                | .63                 | .53 | .31          | .344 | 8,100       |
| 12-8 TRW  | 3/4                 | 1/2                       | II   | 1.29 | .750                | .78                 | .69 | .44          | .406 | 7,300       |
| 12-10 TRW | 3/4                 | 5/8                       | II   | 1.40 | .750                | .94                 | .69 | .50          | .469 | 6,600       |
| 16-4 TRW  | 1                   | 1/4                       | III  | 1.44 | 1.000               | .50                 | .44 | .19          | .250 | 9,600       |
| 16-6 TRW  | 1                   | 3/8                       | III  | 1.50 | 1.000               | .63                 | .53 | .31          | .344 | 8,100       |
| 16-8 TRW  | 1                   | 1/2                       | III  | 1.51 | 1.000               | .78                 | .59 | .44          | .406 | 7,300       |
| 16-10 TRW | 1                   | 5/8                       | III  | 1.52 | 1.000               | .94                 | .66 | .50          | .469 | 6,600       |
| 16-12 TRW | 1                   | 3/4                       | II   | 1.47 | 1.000               | 1.09                | .75 | .66          | .500 | 6,000       |
| 20-4 TRW  | 1-1/4               | 1/4                       | III  | 1.65 | 1.250               | .50                 | .44 | .19          | .250 | 9,600       |
| 20-6 TRW  | 1-1/4               | 3/8                       | III  | 1.68 | 1.250               | .63                 | .53 | .31          | .344 | 8,100       |
| 20-8 TRW  | 1-1/4               | 1/2                       | III  | 1.73 | 1.250               | .78                 | .59 | .44          | .406 | 7,300       |
| 20-12 TRW | 1-1/4               | 3/4                       | III  | 1.73 | 1.250               | 1.09                | .69 | .66          | .500 | 6,000       |
| 20-16 TRW | 1-1/4               | 1                         | II   | 1.68 | 1.250               | 1.44                | .88 | .91          | .563 | 4,900       |
| 24-12 TRW | 1-1/2               | 3/4                       | III  | 1.85 | 1.500               | 1.09                | .69 | .66          | .500 | 6,000       |
| 24-16 TRW | 1-1/2               | 1                         | III  | 1.81 | 1.50                | 1.34                | .75 | .91          | .563 | 4,900       |
| 24-20 TRW | 1-1/2               | 1-1/4                     | II   | 1.70 | 1.500               | 1.75                | .81 | 1.06         | .625 | 4,600       |

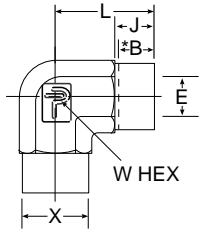
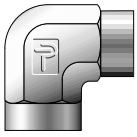
\*Socket Depth

**NOTE:** Other drop sizes available upon request.  
Dimensions for reference only, subject to change.

# Weld-lok® Socket Weld Tube Fittings

## Elbow

EW • tube socket end – both ports

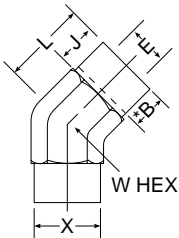


| PART NO. | TUBE O.D. <sub>1</sub> | TUBE O.D. <sub>2</sub> | E SMALL BORE | *B   | L         | J       | W HEX   | X DIA.  | WORK. PRES. |
|----------|------------------------|------------------------|--------------|------|-----------|---------|---------|---------|-------------|
| 2 EW     | 1/8                    | 1/8                    | .09          | .156 | .70       | .34     | 1/2     | .375    | 10,200      |
| 3 EW     | 3/16                   | 3/16                   | .14          | .203 | .75       | .39     | 1/2     | .438    | 9,600       |
| 4 EW     | 1/4                    | 1/4                    | .19          | .250 | .84       | .44     | 9/16    | .500    | 9,600       |
| 5 EW     | 5/16                   | 5/16                   | .25          | .313 | .90       | .50     | 9/16    | .594    | 9,900       |
| 6-4 EW   | 3/8                    | 1/4                    | .19          | .344 | 1.08-.98  | .53-.44 | 13/16   | .63-.50 | 8,100       |
| 6 EW     | 3/8                    | 3/8                    | .31          | .344 | 1.08      | .53     | 13/16   | .625    | 8,100       |
| 8-4 EW   | 1/2                    | 1/4                    | .19          | .406 | 1.14-.98  | .59-.44 | 7/8     | .78-.50 | 7,300       |
| 8-6 EW   | 1/2                    | 3/8                    | .31          | .406 | 1.14-1.08 | .59-.53 | 7/8     | .78-.63 | 7,300       |
| 8 EW     | 1/2                    | 1/2                    | .44          | .406 | 1.14      | .59     | 7/8     | .781    | 7,300       |
| 10 EW    | 5/8                    | 5/8                    | .50          | .469 | 1.36      | .66     | 1-1/16  | .938    | 6,600       |
| 12 EW    | 3/4                    | 3/4                    | .66          | .500 | 1.39      | .69     | 1-1/16  | 1.094   | 6,000       |
| 14 EW    | 7/8                    | 7/8                    | .78          | .500 | 1.58      | .69     | 1-3/8   | 1.312   | 5,700       |
| 16 EW    | 1                      | 1                      | .91          | .563 | 1.84      | .75     | 1-5/8   | 1.438   | 4,400       |
| 20 EW    | 1-1/4                  | 1-1/4                  | 1.06         | .625 | 2.10      | .81     | 1-7/8   | 1.750   | 4,600       |
| 24 EW    | 1-1/2                  | 1-1/2                  | 1.31         | .670 | 2.54      | .86     | 1-1/2   | 2.000   | 3,700       |
| 32 EW    | 2                      | 2                      | 1.81         | .781 | 2.78      | .97     | 2-13/16 | 2.625   | 3,300       |

\*Socket Depth

## 45° Elbow

NW • tube socket – both ends

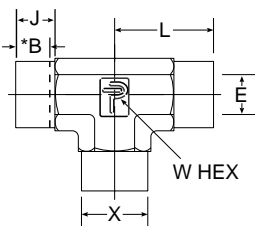
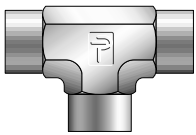


| PART PART NO. | TUBE O.D. | TUBE O.D. | E SMALL BORE | L     | X DIA. | W HEX  | *B   | J   | WORK. PRES. |
|---------------|-----------|-----------|--------------|-------|--------|--------|------|-----|-------------|
| 2 NW          | 1/8       | 1/8       | .09          | .53   | .375   | 7/16   | .156 | .34 | 10,200      |
| 3 NW          | 3/16      | 3/16      | .14          | .73   | .438   | 9/16   | .203 | .39 | 9,600       |
| 4 NW          | 1/4       | 1/4       | .19          | .84   | .500   | 9/16   | .250 | .44 | 9,600       |
| 5 NW          | 5/16      | 5/16      | .25          | .86   | .594   | 9/16   | .313 | .50 | 9,900       |
| 6 NW          | 3/8       | 3/8       | .31          | 1.078 | .625   | 7/8    | .344 | .53 | 8,100       |
| 8 NW          | 1/2       | 1/2       | .44          | 1.14  | .781   | 7/8    | .406 | .59 | 7,300       |
| 10 NW         | 5/8       | 5/8       | .50          | 1.36  | .938   | 1-1/16 | .469 | .66 | 6,600       |
| 12 NW         | 3/4       | 3/4       | .66          | 1.34  | 1.094  | 1-1/16 | .500 | .69 | 6,000       |
| 16 NW         | 1         | 1         | .91          | 1.63  | 1.438  | 1-5/8  | .563 | .75 | 4,400       |
| 20 NW         | 1-1/4     | 1-1/4     | 1.06         | 1.63  | 1.75   | 1-7/8  | .625 | .81 | 4,600       |
| 24 NW         | 1-1/2     | 1-1/2     | 1.31         | 1.67  | 2.00   | 2-1/2  | .670 | .86 | 3,700       |
| 32 NW         | 2         | 2         | 1.81         | 1.67  | 2.63   | 2-1/2  | .781 | .97 | 3,300       |

\*Socket Depth

## Tee

JW • tube socket end – all 3 ports



| TUBE PART NO. | TUBE O.D. <sub>1</sub> | TUBE O.D. <sub>2</sub> | TUBE O.D. <sub>3</sub> | E SMALL BORE | *B      | J       | L         | W HEX   | X DIA.    | WORK. PRES. |
|---------------|------------------------|------------------------|------------------------|--------------|---------|---------|-----------|---------|-----------|-------------|
| 2 JW          | 1/8                    | 1/8                    | 1/8                    | .09          | .156    | .34     | .70       | 1/2     | .375      | 10,200      |
| 3 JW          | 3/16                   | 3/16                   | 3/16                   | .14          | .203    | .39     | .75       | 1/2     | .438      | 9,600       |
| 4 JW          | 1/4                    | 1/4                    | 1/4                    | .19          | .250    | .44     | .84       | 9/16    | .500      | 9,600       |
| 5 JW          | 5/16                   | 5/16                   | 5/16                   | .25          | .313    | .50     | .90       | 9/16    | .594      | 9,900       |
| 6-4-4 JW      | 3/8                    | 3/8                    | 1/4                    | .19          | .34-.25 | .53-.44 | 1.08-.99  | 13/16   | .63-.50   | 8,100       |
| 6 JW          | 3/8                    | 3/8                    | 3/8                    | .31          | .344    | .53     | 1.08      | 13/16   | .625      | 8,100       |
| 8-4-4 JW      | 1/2                    | 1/4                    | 1/4                    | .19          | .41-.25 | .59-.44 | 1.14-.98  | 7/8     | .78-.50   | 7,300       |
| 8-6-6 JW      | 1/2                    | 3/8                    | 3/8                    | .31          | .41-.34 | .59-.53 | 1.14-1.08 | 7/8     | .78-.63   | 7,300       |
| 8-8-4 JW      | 1/2                    | 1/2                    | 1/4                    | .19          | .41-.25 | .59-.44 | 1.14-.98  | 7/8     | .78-.50   | 7,300       |
| 8-8-6 JW      | 1/2                    | 1/2                    | 3/8                    | .31          | .41-.34 | .59-.53 | 1.14-1.08 | 7/8     | .78-.63   | 7,300       |
| 8 JW          | 1/2                    | 1/2                    | 1/2                    | .44          | .406    | .59     | 1.14      | 7/8     | .781      | 7,300       |
| 10 JW         | 5/8                    | 5/8                    | 5/8                    | .50          | .469    | .66     | 1.36      | 1-1/16  | .938      | 6,600       |
| 12-8-12 JW    | 3/4                    | 1/2                    | 3/4                    | .44          | .50-.41 | .69-.59 | 1.39-1.29 | 1-1/16  | 1.09-.78  | 6,000       |
| 12 JW         | 3/4                    | 3/4                    | 3/4                    | .66          | .500    | .69     | 1.39      | 1-1/16  | 1.094     | 6,000       |
| 14 JW         | 7/8                    | 7/8                    | 7/8                    | .78          | .500    | .69     | 1.58      | 1-3/8   | 1.312     | 5,700       |
| 16-8-16 JW    | 1                      | 1.2                    | 1                      | .44          | .56-.41 | .75-.59 | 1.84-1.68 | 1-5/8   | 1.44-.78  | 4,400       |
| 16-12-16 JW   | 1                      | 3/4                    | 1                      | .66          | .56-.50 | .75-.69 | 1.84-1.77 | 1-5/8   | 1.44-1.09 | 4,400       |
| 16 JW         | 1                      | 1                      | 1                      | .91          | .563    | .750    | 1.84      | 1-5/8   | 1.44      | 4,400       |
| 20-16-20 JW   | 1-1/4                  | 1                      | 1-1/4                  | .91          | .63-.56 | .81-.75 | 2.10-2.04 | 1-7/8   | 1.75-1.44 | 4,600       |
| 20 JW         | 1-1/4                  | 1-1/4                  | 1-1/4                  | 1.06         | .625    | .812    | 2.102     | 1-7/8   | 1.750     | 4,600       |
| 24-16-24 JW   | 1-1/2                  | 1                      | 1-1/2                  | .91          | .67-.56 | .86-.75 | 2.54-2.44 | 2-1/2   | 2.00-1.44 | 3,700       |
| 24 JW         | 1-1/2                  | 1-1/2                  | 1-1/2                  | 1.31         | .670    | .857    | 2.54      | 2-1/2   | 2.000     | 3,700       |
| 32 JW         | 2                      | 2                      | 2                      | 1.81         | .781    | .968    | 2.78      | 2-13/16 | 2.625     | 3,300       |

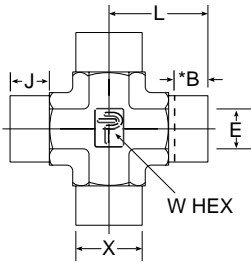
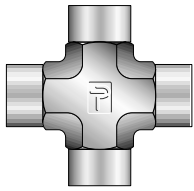
\*Socket Depth

**NOTE:** Other drop sizes available upon request.  
Dimensions for reference only, subject to change.

# Weld-lok® Socket Weld Tube Fittings

## Cross

KW • tube socket end – all 4 ports

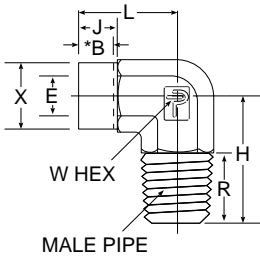
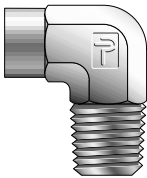


| PART NO. | TUBE O.D. | E SMALL BORE | *B   | J   | L    | W HEX  | X DIA. | WORK. PRES. |
|----------|-----------|--------------|------|-----|------|--------|--------|-------------|
| 2 KW     | 1/8       | .09          | 1.56 | .34 | .70  | 1/2    | .375   | 10,200      |
| 3 KW     | 3/16      | .14          | .203 | .39 | .75  | 1/2    | .438   | 9,600       |
| 4 KW     | 1/4       | .19          | .250 | .44 | .84  | 9/16   | .500   | 9,600       |
| 5 KW     | 5/16      | .25          | .313 | .50 | .90  | 9/16   | .594   | 9,900       |
| 6 KW     | 3/8       | .31          | .344 | .53 | 1.08 | 13/16  | .625   | 8,100       |
| 8 KW     | 1/2       | .44          | .406 | .59 | 1.14 | 13/16  | .781   | 7,300       |
| 10 KW    | 5/8       | .50          | .469 | .66 | 1.36 | 1-1/16 | .938   | 6,600       |
| 12 KW    | 3/4       | .66          | .500 | .69 | 1.39 | 1-1/16 | 1.094  | 6,000       |
| 16 KW    | 1         | .91          | .563 | .75 | 1.84 | 1-5/8  | 1.438  | 4,400       |
| 20 KW    | 1-1/4     | 1.06         | .625 | .81 | 2.10 | 1-7/8  | 1.750  | 4,600       |
| 24 KW    | 1-1/2     | 1.31         | .670 | .86 | 2.54 | 2-9/16 | 2.000  | 3,700       |
| 32 KW    | 2         | 1.81         | .781 | .97 | 2.78 | 2-9/16 | 2.625  | 3,300       |

\*Socket Depth

## Male Elbow

CW • tube socket end – male pipe end



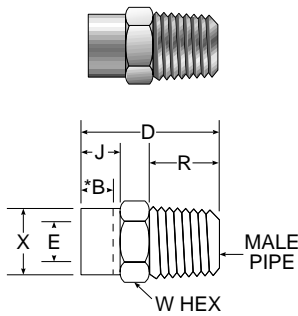
| PART NO. | TUBE O.D. | MALE PIPE | E SMALL BORE | *B   | H    | J   | L    | R    | W HEX  | X DIA. | WORK. PRES. |
|----------|-----------|-----------|--------------|------|------|-----|------|------|--------|--------|-------------|
| 2 CW     | 1/8       | 1/8       | .09          | .156 | .74  | .34 | .70  | .38  | 1/2    | .375   | 9,100       |
| 2-4 CW   | 1/8       | 1/4       | .09          | .156 | .93  | .34 | .70  | .56  | 1/2    | .375   | 7,500       |
| 3 CW     | 3/16      | 1/8       | .14          | .203 | .74  | .39 | .75  | .38  | 1/2    | .438   | 9,100       |
| 4 CW     | 1/4       | 1/8       | .19          | .250 | .79  | .44 | .84  | .38  | 9/16   | .500   | 9,100       |
| 4-4 CW   | 1/4       | 1/4       | .19          | .250 | .97  | .44 | .84  | .56  | 9/16   | .500   | 7,500       |
| 5 CW     | 5/16      | 1/8       | .25          | .313 | .79  | .50 | .90  | .38  | 9/16   | .594   | 9,100       |
| 6 CW     | 3/8       | 1/4       | .31          | .344 | 1.12 | .53 | 1.08 | .56  | 13/16  | .625   | 7,500       |
| 6-6 CW   | 3/8       | 3/8       | .31          | .344 | 1.12 | .53 | 1.08 | .56  | 13/16  | .625   | 7,200       |
| 6-8 CW   | 3/8       | 1/2       | .31          | .344 | 1.31 | .53 | 1.08 | .75  | 13/16  | .625   | 5,800       |
| 8-4 CW   | 1/2       | 1/4       | .44          | .406 | 1.12 | .59 | 1.14 | .56  | 7/8    | .78    | 7,300       |
| 8 CW     | 1/2       | 3/8       | .44          | .406 | 1.12 | .59 | 1.14 | .56  | 7/8    | .78    | 7,200       |
| 8-8 CW   | 1/2       | 1/2       | .44          | .406 | 1.31 | .59 | 1.14 | .75  | 13/16  | .78    | 5,800       |
| 10 CW    | 5/8       | 1/2       | .50          | .469 | 1.46 | .66 | 1.36 | .75  | 1-1/16 | .94    | 5,800       |
| 12-4 CW  | 3/4       | 1/4       | .66          | .500 | 1.27 | .69 | 1.39 | .56  | 1-1/16 | 1.09   | 6,000       |
| 12-8 CW  | 3/4       | 1/2       | .66          | .500 | 1.46 | .69 | 1.39 | .75  | 1-1/16 | 1.09   | 5,800       |
| 12 CW    | 3/4       | 3/4       | .66          | .500 | 1.46 | .69 | 1.39 | .75  | 1-1/16 | 1.09   | 6,000       |
| 16-12 CW | 1         | 3/4       | .72          | .563 | 1.84 | .75 | 1.84 | .75  | 1-5/8  | 1.44   | 4,900       |
| 16 CW    | 1         | 1         | .91          | .563 | 2.03 | .75 | 1.84 | .94  | 1-5/8  | 1.44   | 4,400       |
| 20 CW    | 1-1/4     | 1-1/4     | 1.06         | .625 | 2.27 | .81 | 2.10 | .97  | 1-7/8  | 1.750  | 3,500       |
| 24 CW    | 1-1/2     | 1-1/2     | 1.31         | .670 | 2.69 | .86 | 2.54 | 1.00 | 2-1/2  | 2.000  | 2,900       |

\*Socket Depth

**NOTE:** Other drop sizes available upon request.  
Dimensions for reference only, subject to change.

## Male Connector

FW • tube socket end – male pipe end

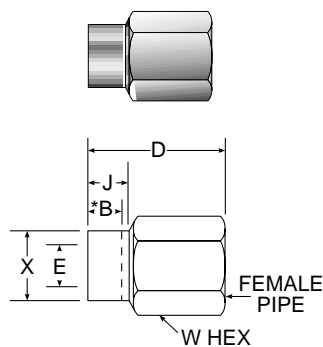


| PART NO. | TUBE O.D. | MALE SOCK. | E SMALL BORE | *B   | D    | J   | R    | W HEX  | X DIA. | WORK. PRES. |
|----------|-----------|------------|--------------|------|------|-----|------|--------|--------|-------------|
| 2 FW     | 1/8       | 1/8        | .09          | .156 | .94  | .34 | .38  | 7/16   | .375   | 9,100       |
| 2-4 FW   | 1/8       | 1/4        | .09          | .156 | 1.14 | .34 | .56  | 9/16   | .375   | 7,500       |
| 3 FW     | 3/16      | 1/8        | .14          | .203 | .94  | .39 | .38  | 1/2    | .438   | 9,100       |
| 3-4 FW   | 3/16      | 1/4        | .14          | .203 | 1.19 | .39 | .56  | 9/16   | .438   | 7,500       |
| 4 FW     | 1/4       | 1/8        | .19          | .250 | 1.05 | .44 | .38  | 9/16   | .500   | 9,100       |
| 4-4 FW   | 1/4       | 1/4        | .19          | .250 | 1.23 | .44 | .56  | 9/16   | .500   | 7,500       |
| 4-8 FW   | 1/4       | 1/2        | .19          | .250 | 1.50 | .44 | .75  | 7/8    | .500   | 6,600       |
| 5 FW     | 5/16      | 1/8        | .25          | .313 | 1.13 | .50 | .38  | 5/8    | .594   | 9,100       |
| 6-2 FW   | 3/8       | 1/8        | .19          | .344 | 1.16 | .53 | .38  | 11/16  | .625   | 8,100       |
| 6 FW     | 3/8       | 1/4        | .28          | .344 | 1.34 | .53 | .56  | 11/16  | .625   | 7,500       |
| 6-6 FW   | 3/8       | 3/8        | .31          | .344 | 1.34 | .53 | .56  | 11/16  | .625   | 7,200       |
| 6-8 FW   | 3/8       | 1/2        | .31          | .344 | 1.59 | .53 | .75  | 7/8    | .625   | 6,600       |
| 6-12 FW  | 3/8       | 3/4        | .31          | .344 | 1.66 | .53 | .75  | 1-1/16 | .625   | 6,400       |
| 8-2 FW   | 1/2       | 1/8        | .19          | .406 | 1.25 | .59 | .38  | 13/16  | .781   | 7,300       |
| 8-4 FW   | 1/2       | 1/4        | .28          | .406 | 1.44 | .59 | .56  | 13/16  | .781   | 7,300       |
| 8 FW     | 1/2       | 3/8        | .41          | .406 | 1.44 | .59 | .56  | 13/16  | .781   | 7,200       |
| 8-8 FW   | 1/2       | 1/2        | .44          | .406 | 1.66 | .59 | .75  | 7/8    | .781   | 6,600       |
| 8-12 FW  | 1/2       | 3/4        | .44          | .406 | 1.72 | .59 | .75  | 1-1/16 | .781   | 6,400       |
| 10-4 FW  | 5/8       | 1/4        | .28          | .469 | 1.56 | .66 | .56  | 1      | .938   | 6,600       |
| 10-6 FW  | 5/8       | 3/8        | .41          | .469 | 1.56 | .66 | .56  | 1      | .938   | 6,600       |
| 10 FW    | 5/8       | 1/2        | .50          | .469 | 1.75 | .66 | .75  | 1      | .938   | 6,600       |
| 10-12 FW | 5/8       | 3/4        | .50          | .469 | 1.78 | .66 | .75  | 1-1/16 | .938   | 6,400       |
| 12-8 FW  | 3/4       | 1/2        | .50          | .500 | 1.81 | .69 | .75  | 1-1/8  | 1.094  | 6,000       |
| 12 FW    | 3/4       | 3/4        | .66          | .500 | 1.81 | .69 | .75  | 1-1/8  | 1.094  | 6,000       |
| 12-16 FW | 3/4       | 1          | .66          | .500 | 2.09 | .69 | .94  | 1-3/8  | 1.094  | 4,600       |
| 14 FW    | 7/8       | 3/4        | .66          | .500 | 1.91 | .69 | .75  | 1-3/8  | 1.312  | 5,700       |
| 16-8 FW  | 1         | 1/2        | .50          | .563 | 2.02 | .75 | .75  | 1-5/8  | 1.438  | 4,900       |
| 16-12 FW | 1         | 3/4        | .72          | .563 | 2.02 | .75 | .75  | 1-5/8  | 1.438  | 4,900       |
| 16 FW    | 1         | 1          | .91          | .563 | 2.20 | .75 | .94  | 1-5/8  | 1.438  | 4,600       |
| 20-12 FW | 1-1/4     | 3/4        | .72          | .625 | 2.14 | .81 | .75  | 1-7/8  | 1.750  | 4,600       |
| 20-16 FW | 1-1/4     | 1          | .94          | .625 | 2.33 | .81 | .94  | 1-7/8  | 1.750  | 4,600       |
| 20 FW    | 1-1/4     | 1-1/4      | 1.06         | .625 | 2.36 | .81 | .97  | 1-7/8  | 1.750  | 3,500       |
| 20-24 FW | 1-1/4     | 1-1/2      | 1.06         | .625 | 2.42 | .81 | 1.00 | 2      | 1.750  | 2,900       |
| 24-20 FW | 1-1/2     | 1-1/4      | 1.25         | .670 | 2.49 | .86 | .97  | 2-1/8  | 2.000  | 3,500       |
| 24 FW    | 1-1/2     | 1-1/2      | 1.31         | .670 | 2.52 | .86 | 1.00 | 2-1/8  | 2.000  | 2,900       |
| 32 FW    | 2         | 2          | 1.81         | .781 | 2.97 | .97 | 1.03 | 2-3/4  | 2.625  | 2,600       |

\*Socket Depth

## Female Connector

GW • tube socket end – female pipe end



| PART PART NO. | TUBE O.D. | FEMALE PIPE | E SMALL BORE | *B   | D    | J   | W HEX  | X DIA. | WORK. PRES. |
|---------------|-----------|-------------|--------------|------|------|-----|--------|--------|-------------|
| 2 GW          | 1/8       | 1/8         | .09          | .156 | .95  | .34 | 9/16   | .375   | 6,400       |
| 3 GW          | 3/16      | 1/8         | .14          | .203 | .98  | .39 | 9/16   | .438   | 6,400       |
| 4 GW          | 1/4       | 1/8         | .19          | .250 | 1.01 | .44 | 9/16   | .500   | 6,400       |
| 4-4 GW        | 1/4       | 1/4         | .19          | .250 | 1.26 | .44 | 3/4    | .500   | 6,600       |
| 4-12 GW       | 1/4       | 3/4         | .19          | .250 | 1.80 | .44 | 1-1/4  | .500   | 4,300       |
| 5 GW          | 5/16      | 1/8         | .25          | .313 | 1.07 | .50 | 5/8    | .594   | 6,400       |
| 6-2 GW        | 3/8       | 1/8         | .31          | .344 | 1.11 | .53 | 11/16  | .625   | 6,400       |
| 6 GW          | 3/8       | 1/4         | .31          | .344 | 1.32 | .53 | 3/4    | .625   | 6,600       |
| 6-6 GW        | 3/8       | 3/8         | .31          | .344 | 1.42 | .53 | 15/16  | .625   | 5,300       |
| 6-8 GW        | 3/8       | 1/2         | .31          | .344 | 1.67 | .53 | 1-1/16 | .625   | 5,200       |
| 6-12 GW       | 3/8       | 3/4         | .31          | .344 | 1.86 | .53 | 1-1/4  | .625   | 4,300       |
| 6-16 GW       | 3/8       | 1           | .31          | .344 | 2.30 | .53 | 1-5/8  | .625   | 4,500       |
| 8-2 GW        | 1/2       | 1/8         | .34          | .406 | 1.17 | .59 | 13/16  | .781   | 6,400       |
| 8-4 GW        | 1/2       | 1/4         | .44          | .406 | 1.36 | .59 | 13/16  | .781   | 6,600       |
| 8 GW          | 1/2       | 3/8         | .44          | .406 | 1.44 | .59 | 7/8    | .781   | 5,300       |
| 8-8 GW        | 1/2       | 1/2         | .44          | .406 | 1.69 | .59 | 1-1/16 | .781   | 5,200       |
| 10-6 GW       | 5/8       | 3/8         | .50          | .469 | 1.52 | .66 | 1-1/16 | .938   | 5,300       |
| 10 GW         | 5/8       | 1/2         | .50          | .469 | 1.71 | .66 | 1-1/16 | .938   | 5,200       |
| 10-16 GW      | 5/8       | 1           | .50          | .469 | 2.33 | .66 | 1-5/8  | .938   | 4,500       |
| 12-8 GW       | 3/4       | 1/2         | .66          | .500 | 1.72 | .69 | 1-1/8  | 1.094  | 5,200       |
| 12 GW         | 3/4       | 3/4         | .66          | .500 | 1.88 | .69 | 1-1/4  | 1.094  | 4,300       |
| 14 GW         | 7/8       | 3/4         | .78          | .500 | 1.86 | .69 | 1-3/8  | 1.312  | 4,300       |
| 16-8 GW       | 1         | 1/2         | .71          | .563 | 1.85 | .75 | 1-5/8  | 1.438  | 4,900       |
| 16-12 GW      | 1         | 3/4         | .91          | .563 | 1.97 | .75 | 1-5/8  | 1.438  | 4,300       |
| 16 GW         | 1         | 1           | .91          | .563 | 2.28 | .75 | 1-5/8  | 1.438  | 4,500       |
| 20 GW         | 1-1/4     | 1-1/4       | 1.06         | .625 | 2.39 | .81 | 2      | 1.750  | 3,500       |

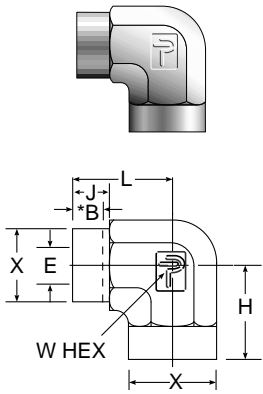
\*Socket Depth

**NOTE:** Other drop sizes available upon request.  
Dimensions for reference only, subject to change.

# Weld-lok® Socket Weld Tube Fittings

## Female Elbow

DW • tube socket end – female pipe end

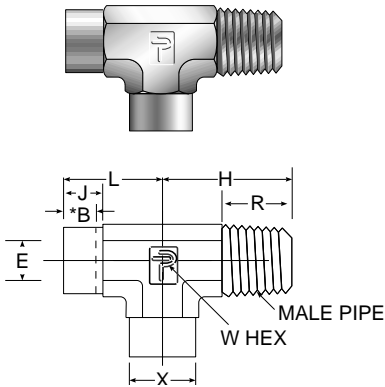


| PART NO. | TUBE O.D. | FEMALE PIPE | E SMALL BORE | *B   | H    | J   | L    | W HEX  | X DIA. | WORK. PRES. |
|----------|-----------|-------------|--------------|------|------|-----|------|--------|--------|-------------|
| 2 DW     | 1/8       | 1/8         | .09          | .156 | .75  | .34 | .70  | 1/2    | .375   | 5,500       |
| 3 DW     | 3/16      | 1/8         | .14          | .203 | .75  | .39 | .75  | 1/2    | .438   | 5,500       |
| 4 DW     | 1/4       | 1/8         | .19          | .250 | .75  | .44 | .84  | 9/16   | .500   | 5,500       |
| 4-4 DW   | 1/4       | 1/4         | .19          | .250 | .88  | .44 | .91  | 11/16  | .500   | 5,600       |
| 5 DW     | 5/16      | 1/8         | .25          | .313 | .75  | .50 | .90  | 9/16   | .594   | 5,500       |
| 6 DW     | 3/8       | 1/4         | .31          | .344 | .88  | .53 | 1.00 | 11/16  | .625   | 5,600       |
| 6-6 DW   | 3/8       | 3/8         | .31          | .344 | .88  | .53 | 1.08 | 13/16  | .625   | 5,000       |
| 6-8 DW   | 3/8       | 1/2         | .31          | .344 | 1.12 | .53 | 1.19 | 1      | .625   | 4,500       |
| 8-4 DW   | 1/2       | 1/4         | .44          | .406 | .88  | .59 | 1.14 | 7/8    | .781   | 5,600       |
| 8 DW     | 1/2       | 3/8         | .44          | .406 | .88  | .59 | 1.14 | 13/16  | .781   | 5,000       |
| 8-8 DW   | 1/2       | 1/2         | .44          | .406 | 1.12 | .59 | 1.29 | 1-1/16 | .781   | 4,500       |
| 10 DW    | 5/8       | 1/2         | .50          | .469 | 1.12 | .66 | 1.36 | 1-1/16 | .938   | 4,500       |
| 12-4 DW  | 3/4       | 1/4         | .66          | .500 | 1.12 | .69 | 1.39 | 1-1/16 | 1.094  | 5,600       |
| 12 DW    | 3/4       | 3/4         | .66          | .500 | 1.25 | .69 | 1.58 | 1-5/16 | 1.094  | 3,500       |
| 14-12 DW | 7/8       | 3/4         | .78          | .500 | 1.25 | .69 | 1.58 | 1-3/8  | 1.312  | 3,500       |
| 16-6 DW  | 1         | 3/8         | .91          | .563 | 1.75 | .75 | 1.84 | 1-5/8  | 1.438  | 4,900       |
| 16 DW    | 1         | 1           | .91          | .563 | 1.50 | .75 | 1.84 | 1-5/8  | 1.438  | 3,900       |
| 20 DW    | 1-1/4     | 1-1/4       | 1.06         | .625 | 1.88 | .81 | 2.10 | 1-7/8  | 1.750  | 3,100       |
| 24-16 DW | 1-1/2     | 1           | 1.31         | .670 | 2.08 | .86 | 2.54 | 2-1/2  | 2.000  | 3,700       |
| 24 DW    | 1-1/2     | 1-1/2       | 1.31         | .670 | 2.13 | .86 | 2.54 | 2-1/2  | 2.000  | 2,500       |

\*Socket Depth

## Male Run Tee

RW • socket weld – male run tee

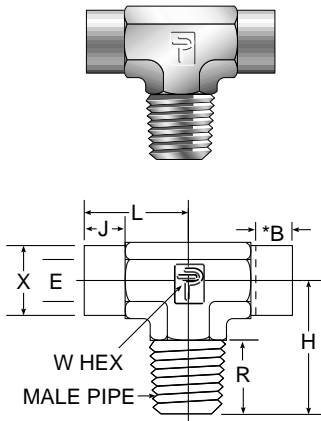


| PART NO. | TUBE O.D. | MALE PIPE | E SMALL BORE | L    | H    | X DIA. | W HEX   | *B   | J   | R    | WORK. PRES. |
|----------|-----------|-----------|--------------|------|------|--------|---------|------|-----|------|-------------|
| 2 RW     | 1/8       | 1/8       | .09          | .70  | .74  | .375   | 1/2     | .156 | .34 | .38  | 9,100       |
| 3 RW     | 3/16      | 1/8       | .14          | .75  | .75  | .438   | 1/2     | .203 | .39 | .38  | 9,100       |
| 4 RW     | 1/4       | 1/8       | .19          | .84  | .79  | .500   | 9/16    | .250 | .44 | .38  | 9,100       |
| 5 RW     | 5/16      | 1/8       | .19          | .90  | .79  | .594   | 9/16    | .313 | .50 | .38  | 9,100       |
| 6 RW     | 3/8       | 1/4       | .28          | 1.08 | 1.12 | .625   | 13/16   | .344 | .53 | .56  | 7,500       |
| 8 RW     | 1/2       | 3/8       | .41          | 1.14 | 1.12 | .781   | 13/16   | .406 | .59 | .56  | 7,200       |
| 10 RW    | 5/8       | 1/2       | .50          | 1.36 | 1.46 | .938   | 1-1/16  | .469 | .66 | .75  | 5,800       |
| 12 RW    | 3/4       | 3/4       | .656         | 1.39 | 1.46 | 1.094  | 1-1/16  | .500 | .69 | .75  | 6,000       |
| 14 RW    | 7/8       | 3/4       | .719         | 1.58 | 1.65 | 1.312  | 1-3/8   | .500 | .69 | .75  | 5,700       |
| 16 RW    | 1         | 1         | .906         | 1.84 | 2.03 | 1.438  | 1-5/16  | .563 | .75 | .94  | 4,400       |
| 20 RW    | 1-1/4     | 1-1/4     | 1.063        | 2.10 | 2.27 | 1.750  | 1-7/8   | .625 | .81 | .97  | 3,500       |
| 24 RW    | 1-1/2     | 1-1/2     | 1.313        | 2.54 | 2.70 | 2.000  | 2-1/2   | .670 | .86 | 1.00 | 2,900       |
| 32 RW    | 2         | 2         | 1.813        | 2.78 | 2.85 | 2.625  | 2-13/16 | .781 | .97 | 1.03 | 2,600       |

\*Socket Depth

## Male Branch Tee

SW • socket weld – male outlet tee



| PART NO. | TUBE O.D. | MALE PIPE | E SMALL BORE | L    | H    | X DIA. | W HEX   | *B   | J   | R    | WORK. PRES. |
|----------|-----------|-----------|--------------|------|------|--------|---------|------|-----|------|-------------|
| 2 SW     | 1/8       | 1/8       | .09          | .70  | .74  | .375   | 1/2     | .156 | .34 | .38  | 9,100       |
| 3 SW     | 3/16      | 1/8       | .14          | .75  | .75  | .438   | 1/2     | .203 | .39 | .38  | 9,100       |
| 4 SW     | 1/4       | 1/8       | .19          | .84  | .79  | .500   | 9/16    | .250 | .44 | .38  | 9,100       |
| 5 SW     | 5/16      | 1/8       | .19          | .90  | .79  | .594   | 9/16    | .313 | .50 | .38  | 9,100       |
| 6 SW     | 3/8       | 1/4       | .28          | 1.08 | 1.12 | .625   | 13/16   | .344 | .53 | .56  | 7,500       |
| 8 SW     | 1/2       | 3/8       | .41          | 1.14 | 1.12 | .781   | 13/16   | .406 | .59 | .56  | 7,200       |
| 10 SW    | 5/8       | 1/2       | .50          | 1.36 | 1.47 | .938   | 1-1/16  | .469 | .66 | .75  | 5,800       |
| 12 SW    | 3/4       | 3/4       | .66          | 1.39 | 1.46 | 1.094  | 1-1/16  | .500 | .69 | .75  | 6,000       |
| 14 SW    | 7/8       | 3/4       | .72          | 1.58 | 1.65 | 1.312  | 1-3/8   | .500 | .69 | .75  | 5,700       |
| 16 SW    | 1         | 1         | .91          | 1.84 | 2.03 | 1.438  | 1-5/16  | .563 | .75 | .94  | 4,400       |
| 20 SW    | 1-1/4     | 1-1/4     | 1.06         | 2.10 | 2.27 | 1.750  | 1-7/8   | .625 | .81 | .97  | 3,500       |
| 24 SW    | 1-1/2     | 1-1/2     | 1.31         | 2.54 | 2.70 | 2.000  | 2-1/2   | .670 | .86 | 1.00 | 2,900       |
| 32 SW    | 2         | 2         | 1.81         | 2.78 | 2.85 | 2.625  | 2-13/16 | .781 | .97 | 1.03 | 2,600       |

\*Socket Depth

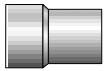
**NOTE:** Other drop sizes available upon request.  
Dimensions for reference only, subject to change.

# Weld-lok® Socket Weld Tube Fittings

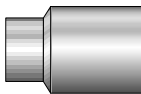
## Adapter

**AW** • tube socket end – adapter end for welding into a female pipe size welding boss

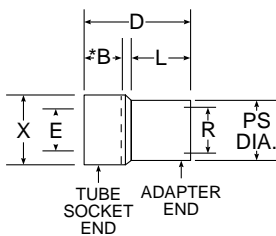
**TYPE I**



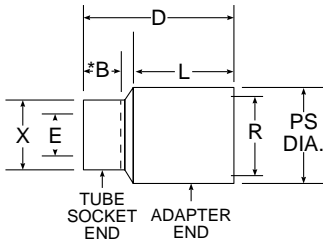
**TYPE II**



**TYPE I**



**TYPE II**



| PART NO.    | TYPE | TUBE O.D. | PIPE SIZE | PIPE SIZE O.D. | R BORE | X DIA. | L    | D    | *B  | E BORE | WORK. PRES. |
|-------------|------|-----------|-----------|----------------|--------|--------|------|------|-----|--------|-------------|
| 2-1/8 AW    | II   | 1/8       | 1/8       | .41            | .21    | .38    | .38  | .73  | .16 | .09    | 8,700       |
| 2-1/4 AW    | II   | 1/8       | 1/4       | .54            | .30    | .38    | .56  | .95  | .16 | .09    | 8,200       |
| 3-1/8 AW    | I    | 3/16      | 1/8       | .41            | .21    | .44    | .38  | .76  | .20 | .14    | 8,700       |
| 3-1/2 AW    | II   | 3/16      | 1/2       | .84            | .55    | .44    | .75  | 1.26 | .20 | .14    | 6,400       |
| 3-3/4 AW    | I    | 3/16      | 3/4       | 1.05           | .73    | .44    | .75  | 1.32 | .20 | .14    | 5,300       |
| 4-1/8 AW    | I    | 1/4       | 1/8       | .41            | .21    | .50    | .38  | .84  | .25 | .19    | 8,700       |
| 4-1/4 AW    | II   | 1/4       | 1/4       | .54            | .30    | .50    | .56  | 1.01 | .25 | .19    | 8,200       |
| 4-3/8 AW    | II   | 1/4       | 3/8       | .68            | .42    | .50    | .56  | 1.05 | .25 | .19    | 6,900       |
| 4-1/2 AW    | II   | 1/4       | 1/2       | .84            | .55    | .50    | .75  | 1.29 | .25 | .19    | 6,400       |
| 4-3/4 AW    | II   | 1/4       | 3/4       | 1.05           | .73    | .50    | .75  | 1.35 | .25 | .19    | 5,300       |
| 4-1 AW      | II   | 1/4       | 1         | 1.31           | .95    | .50    | .94  | 1.61 | .25 | .19    | 4,900       |
| 5-1/8 AW    | I    | 5/16      | 1/8       | .41            | .21    | .59    | .38  | .93  | .31 | .21    | 8,700       |
| 5-1/2 AW    | II   | 5/16      | 1/2       | .84            | .55    | .59    | .75  | 1.32 | .31 | .25    | 6,400       |
| 6-1/4 AW    | I    | 3/8       | 1/4       | .54            | .30    | .63    | .56  | 1.12 | .34 | .30    | 8,100       |
| 6-3/8 AW    | II   | 3/8       | 3/8       | .68            | .42    | .63    | .56  | 1.11 | .34 | .31    | 6,900       |
| 6-1/2 AW    | II   | 3/8       | 1/2       | .84            | .55    | .63    | .75  | 1.34 | .34 | .31    | 6,400       |
| 6-3/4 AW    | II   | 3/8       | 3/4       | 1.05           | .73    | .63    | .75  | 1.40 | .34 | .31    | 5,300       |
| 6-1 AW      | II   | 3/8       | 1         | 1.31           | .95    | .63    | .94  | 1.67 | .34 | .31    | 4,900       |
| 6-1-1/2 AW  | II   | 3/8       | 1-1/2     | 1.50           | 1.50   | .63    | 1.03 | 1.93 | .34 | .31    | 3,700       |
| 8-1/4 AW    | I    | 1/2       | 1/4       | .54            | .30    | .78    | .56  | 1.23 | .41 | .30    | 8,100       |
| 8-3/8 AW    | I    | 1/2       | 3/8       | .68            | .41    | .78    | .56  | 1.19 | .41 | .41    | 6,900       |
| 8-1/2 AW    | II   | 1/2       | 1/2       | .84            | .55    | .78    | .75  | 1.36 | .41 | .44    | 6,400       |
| 8-3/4 AW    | II   | 1/2       | 3/4       | 1.05           | .73    | .78    | .75  | 1.42 | .41 | .44    | 5,300       |
| 8-1 AW      | II   | 1/2       | 1         | 1.31           | .95    | .78    | .94  | 1.69 | .41 | .44    | 4,900       |
| 10-1/2 AW   | I    | 5/8       | 1/2       | .84            | .55    | .94    | .75  | 1.43 | .47 | .50    | 4,900       |
| 10-3/4 AW   | II   | 5/8       | 3/4       | 1.05           | .73    | .94    | .75  | 1.44 | .47 | .50    | 5,300       |
| 10-1 AW     | II   | 5/8       | 1         | 1.31           | .95    | .94    | .94  | 1.70 | .47 | .50    | 4,900       |
| 12-1/4 AW   | I    | 3/4       | 1/4       | .54            | .30    | 1.09   | .56  | 1.41 | .50 | .30    | 6,000       |
| 12-3/8 AW   | I    | 3/4       | 3/8       | .68            | .42    | 1.09   | .56  | 1.37 | .50 | .42    | 6,000       |
| 12-1/2 AW   | I    | 3/4       | 1/2       | .84            | .55    | 1.09   | .75  | 1.51 | .50 | .55    | 6,000       |
| 12-3/4 AW   | I    | 3/4       | 3/4       | 1.05           | .73    | 1.09   | .75  | 1.45 | .50 | .66    | 5,300       |
| 12-1 AW     | II   | 3/4       | 1         | 1.31           | .95    | 1.09   | .94  | 1.69 | .50 | .66    | 4,900       |
| 16-1/4 AW   | I    | 1         | 1/4       | .54            | .30    | 1.44   | .56  | 1.57 | .56 | .30    | 4,900       |
| 16-3/8 AW   | I    | 1         | 3/8       | .68            | .42    | 1.44   | .56  | 1.53 | .56 | .42    | 4,900       |
| 16-1/2 AW   | I    | 1         | 1/2       | .84            | .55    | 1.44   | .75  | 1.67 | .56 | .55    | 4,900       |
| 16-3/4 AW   | I    | 1         | 3/4       | 1.05           | .73    | 1.44   | .75  | 1.61 | .56 | .73    | 4,900       |
| 16-1 AW     | I    | 1         | 1         | 1.31           | .95    | 1.44   | .94  | 1.72 | .56 | .91    | 4,900       |
| 16-1-1/4 AW | II   | 1         | 1-1/4     | 1.66           | 1.28   | 1.44   | .94  | 1.75 | .56 | .91    | 4,100       |
| 16-1-1/2 AW | II   | 1         | 1-1/2     | 1.90           | 1.50   | 1.44   | 1.03 | 1.91 | .56 | .91    | 3,700       |
| 20-1-1/4 AW | II   | 1-1/4     | 1-1/4     | 1.66           | 1.28   | 1.75   | .94  | 1.78 | .63 | 1.06   | 4,100       |
| 20-1-1/2 AW | II   | 1-1/4     | 1-1/2     | 1.90           | 1.50   | 1.75   | 1.03 | 1.89 | .63 | 1.06   | 3,700       |
| 24-1-1/2 AW | I    | 1-1/2     | 1-1/2     | 1.90           | 1.50   | 2.00   | 1.03 | 1.92 | .67 | 1.31   | 3,700       |
| 32-2 AW     | I    | 2         | 2         | 2.38           | 1.94   | 2.63   | 1.06 | 2.10 | .78 | 1.81   | 3,200       |

**NOTE:** "R" bore diameter will conform to Schedule 80 pipe wall thickness unless otherwise noted.

\*Socket Depth

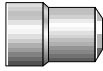
**NOTE:** Other drop sizes available upon request.  
Dimensions for reference only, subject to change.

# Weld-lok® Socket Weld Tube Fittings

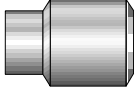
## Adapter

AW2 • tube socket to pipe butt weld

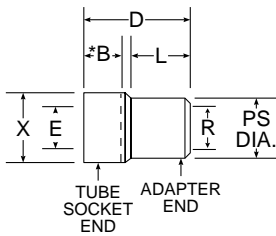
TYPE I



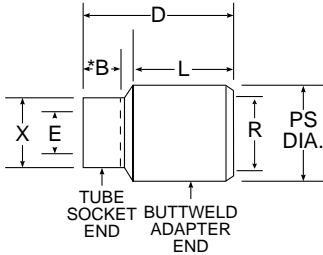
TYPE II



TYPE I



TYPE II



| PART NO.     | TYPE | TUBE O.D. | PIPE SIZE | PIPE SIZE O.D. | R BORE | X DIA. | L    | D    | *B  | E BORE | WORK. PRES. |
|--------------|------|-----------|-----------|----------------|--------|--------|------|------|-----|--------|-------------|
| 2-1/8 AW2    | II   | 1/8       | 1/8       | .41            | .21    | .38    | .38  | .73  | .16 | .09    | 8,700       |
| 2-1/4 AW2    | II   | 1/8       | 1/4       | .54            | .30    | .38    | .56  | .95  | .16 | .09    | 8,200       |
| 3-1/8 AW2    | I    | 3/16      | 1/8       | .41            | .21    | .44    | .38  | .76  | .20 | .14    | 8,700       |
| 3-1/2 AW2    | II   | 3/16      | 1/2       | .84            | .55    | .44    | .75  | 1.26 | .20 | .14    | 6,400       |
| 3-3/4 AW2    | II   | 3/16      | 3/4       | 1.05           | .73    | .44    | .75  | 1.32 | .20 | .14    | 5,300       |
| 4-1/8 AW2    | I    | 1/4       | 1/8       | .41            | .21    | .50    | .38  | .84  | .25 | .19    | 8,700       |
| 4-1/4 AW2    | II   | 1/4       | 1/4       | .54            | .30    | .50    | .56  | 1.01 | .25 | .19    | 8,200       |
| 4-3/8 AW2    | II   | 1/4       | 3/8       | .68            | .42    | .50    | .56  | 1.05 | .25 | .19    | 6,900       |
| 4-1/2 AW2    | II   | 1/4       | 1/2       | .84            | .55    | .50    | .75  | 1.29 | .25 | .19    | 6,400       |
| 4-3/4 AW2    | II   | 1/4       | 3/4       | 1.05           | .73    | .50    | .75  | 1.35 | .25 | .19    | 5,300       |
| 4-1 AW2      | II   | 1/4       | 1         | 1.31           | .95    | .50    | .94  | 1.61 | .25 | .19    | 4,900       |
| 5-1/8 AW2    | I    | 5/16      | 1/8       | .41            | .21    | .59    | .38  | .93  | .31 | .21    | 8,700       |
| 5-1/2 AW2    | II   | 5/16      | 1/2       | .84            | .55    | .59    | .75  | 1.32 | .31 | .25    | 6,400       |
| 6-1/4 AW2    | I    | 3/8       | 1/4       | .54            | .30    | .63    | .56  | 1.12 | .34 | .30    | 8,100       |
| 6-3/8 AW2    | II   | 3/8       | 3/8       | .68            | .42    | .63    | .56  | 1.11 | .34 | .31    | 6,900       |
| 6-1/2 AW2    | II   | 3/8       | 1/2       | .84            | .55    | .63    | .75  | 1.34 | .34 | .31    | 6,400       |
| 6-3/4 AW2    | II   | 3/8       | 3/4       | 1.05           | .73    | .63    | .75  | 1.40 | .34 | .31    | 5,300       |
| 6-1 AW2      | II   | 3/8       | 1         | 1.31           | .95    | .63    | .94  | 1.67 | .34 | .31    | 4,900       |
| 6-1-1/2 AW2  | II   | 3/8       | 1-1/2     | 1.50           | 1.50   | .63    | 1.03 | 1.93 | .34 | .31    | 3,700       |
| 8-1/4 AW2    | I    | 1/2       | 1/4       | .54            | .30    | .78    | .56  | 1.23 | .41 | .30    | 8,100       |
| 8-3/8 AW2    | I    | 1/2       | 3/8       | .68            | .41    | .78    | .56  | 1.19 | .41 | .41    | 6,900       |
| 8-1/2 AW2    | II   | 1/2       | 1/2       | .84            | .55    | .78    | .75  | 1.36 | .41 | .44    | 6,400       |
| 8-3/4 AW2    | II   | 1/2       | 3/4       | 1.05           | .78    | .75    | 1.42 | .41  | .44 | .44    | 5,300       |
| 8-1 AW2      | II   | 1/2       | 1         | 1.31           | .95    | .78    | .94  | 1.69 | .41 | .44    | 4,900       |
| 10-1/2 AW2   | I    | 5/8       | 1/2       | .54            | .30    | .94    | .75  | 1.43 | .47 | .50    | 4,900       |
| 10-3/4 AW2   | II   | 5/8       | 3/4       | 1.05           | .73    | .94    | .75  | 1.44 | .47 | .50    | 5,300       |
| 10-1 AW2     | II   | 5/8       | 1         | 1.31           | .95    | .94    | .94  | 1.70 | .47 | .50    | 4,900       |
| 12-1/4 AW2   | I    | 3/4       | 1/4       | .54            | .30    | 1.09   | .56  | 1.41 | .50 | .30    | 6,000       |
| 12-3/8 AW2   | I    | 3/4       | 3/8       | .68            | .42    | 1.09   | .56  | 1.37 | .50 | .42    | 6,000       |
| 12-1/2 AW2   | I    | 3/4       | 1/2       | .84            | .55    | 1.09   | .75  | 1.51 | .50 | .55    | 6,000       |
| 12-3/4 AW2   | I    | 3/4       | 3/4       | 1.05           | .73    | 1.09   | .75  | 1.45 | .50 | .66    | 5,300       |
| 12-1 AW2     | II   | 3/4       | 1         | 1.31           | .95    | 1.09   | .94  | 1.69 | .50 | .66    | 4,900       |
| 16-1/4 AW2   | I    | 1         | 1/4       | .54            | .30    | 1.44   | .56  | 1.57 | .56 | .30    | 4,900       |
| 16-3/8 AW2   | I    | 1         | 3/8       | .68            | .42    | 1.44   | .56  | 1.53 | .56 | .42    | 4,900       |
| 16-1/2 AW2   | I    | 1         | 1/2       | .84            | .55    | 1.44   | .75  | 1.67 | .56 | .55    | 4,900       |
| 16-3/4 AW2   | I    | 1         | 3/4       | 1.05           | .73    | 1.44   | .75  | 1.61 | .56 | .73    | 4,900       |
| 16-1 AW2     | I    | 1         | 1         | 1.31           | .95    | 1.44   | .94  | 1.72 | .56 | .91    | 4,900       |
| 16-1-1/4 AW2 | II   | 1         | 1-1/4     | 1.66           | 1.28   | 1.44   | .94  | 1.75 | .56 | .91    | 4,100       |
| 16-1-1/2 AW2 | II   | 1         | 1-1/2     | 1.90           | 1.50   | 1.44   | 1.03 | 1.91 | .56 | .91    | 3,700       |
| 20-1-1/4 AW2 | II   | 1-1/4     | 1-1/4     | 1.66           | 1.28   | 1.75   | .94  | 1.78 | .63 | 1.06   | 4,100       |
| 20-1-1/2 AW2 | II   | 1-1/4     | 1-1/2     | 1.90           | 1.50   | 1.75   | 1.03 | 1.89 | .63 | 1.06   | 3,700       |
| 24-1-1/2 AW2 | I    | 1-1/2     | 1-1/2     | 1.90           | 1.50   | 2.00   | 1.03 | 1.92 | .67 | 1.31   | 3,700       |
| 32-2 AW2     | I    | 2         | 2         | 2.38           | 1.94   | 2.63   | 1.06 | 2.10 | .78 | 1.81   | 3,200       |

**NOTE:** "R" bore diameter will conform to Schedule 80 pipe wall thickness unless otherwise noted.

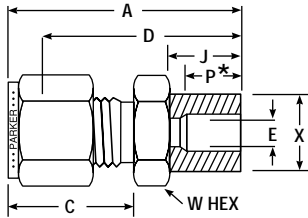
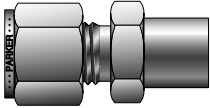
\*Socket Depth

**NOTE:** Other drop sizes available upon request.  
Dimensions for reference only, subject to change.

## ZHBW

Socket weld connector for fractional tube

- for CPI™ to tubing socket weld connection



| PART NO.   | INTER-CHANGES WITH | TUBE O.D. | A    | C    | D    | J   | *P  | X    | E BORE | W HEX  |
|------------|--------------------|-----------|------|------|------|-----|-----|------|--------|--------|
| 1-2 ZHBW   | 100-6-2W           | 1/16      | .99  | .43  | .84  | .34 | .16 | .38  | .09    | 7/16   |
| 1-4 ZHBW   | 100-6-4W           | 1/16      | 1.10 | .43  | .95  | .44 | .25 | .50  | .19    | 9/16   |
| 2-2 ZHBW   | 200-6-2W           | 1/8       | 1.16 | .60  | .90  | .34 | .16 | .38  | .09    | 7/16   |
| 3-3 ZHBW   | 300-6-3W           | 3/16      | 1.25 | .64  | .98  | .39 | .20 | .44  | .13    | 1/2    |
| 4-4 ZHBW   | 400-6-4W           | 1/4       | 1.37 | .70  | 1.08 | .44 | .25 | .50  | .19    | 9/16   |
| 4-6 ZHBW   | 400-6-6W           | 1/4       | 1.47 | .70  | 1.18 | .53 | .34 | .63  | .31    | 11/16  |
| 4-8 ZHBW   | 400-6-8W           | 1/4       | 1.56 | .70  | 1.27 | .59 | .41 | .78  | .44    | 13/16  |
| 4-10 ZHBW  | 400-6-10W          | 1/4       | 1.60 | .70  | 1.31 | .66 | .47 | .94  | .50    | 1      |
| 4-12 ZHBW  | 400-6-12W          | 1/4       | 1.75 | .70  | 1.46 | .69 | .50 | 1.09 | .66    | 1-1/8  |
| 4-16 ZHBW  | 400-6-16W          | 1/4       | 1.88 | .70  | 1.59 | .75 | .56 | 1.38 | .91    | 1-1/2  |
| 6-2 ZHBW   | 600-6-2W           | 3/8       | 1.35 | .76  | 1.06 | .34 | .16 | .38  | .09    | 5/8    |
| 6-6 ZHBW   | 600-6-6W           | 3/8       | 1.53 | .76  | 1.24 | .53 | .34 | .63  | .28    | 11/16  |
| 6-8 ZHBW   | 600-6-8W           | 3/8       | 1.63 | .76  | 1.34 | .59 | .41 | .78  | .44    | 13/16  |
| 6-12 ZHBW  | 600-6-12W          | 3/8       | 1.81 | .76  | 1.52 | .69 | .50 | 1.09 | .66    | 1-1/8  |
| 6-16 ZHBW  | 600-6-16W          | 3/8       | 2.02 | .76  | 1.73 | .75 | .56 | 1.44 | .91    | 1-5/8  |
| 8-2 ZHBW   | 800-6-2W           | 1/2       | 1.49 | .87  | 1.09 | .34 | .16 | .38  | .09    | 13/16  |
| 8-4 ZHBW   | 800-6-4W           | 1/2       | 1.58 | .87  | 1.18 | .44 | .25 | .50  | .19    | 13/16  |
| 8-6 ZHBW   | 800-6-6W           | 1/2       | 1.67 | .87  | 1.27 | .53 | .34 | .63  | .31    | 13/16  |
| 8-8 ZHBW   | 800-6-8W           | 1/2       | 1.74 | .87  | 1.34 | .59 | .41 | .78  | .41    | 13/16  |
| 8-12 ZHBW  | 800-6-12W          | 1/2       | 1.92 | .87  | 1.52 | .69 | .50 | 1.09 | .66    | 1-1/8  |
| 8-16 ZHBW  | 800-6-16W          | 1/2       | 2.53 | .87  | 1.73 | .75 | .56 | 1.44 | .91    | 1-5/8  |
| 10-10 ZHBW | 1010-6-10W         | 5/8       | 1.86 | .87  | 1.46 | .66 | .47 | .94  | .50    | 1      |
| 10-12 ZHBW | 1010-6-12W         | 5/8       | 1.92 | .87  | 1.52 | .69 | .50 | 1.09 | .66    | 1-1/8  |
| 12-4 ZHBW  | 1210-6-4W          | 3/4       | 1.68 | .87  | 1.28 | .44 | .25 | .50  | .19    | 1-1/16 |
| 12-8 ZHBW  | 1210-6-8W          | 3/4       | 1.84 | .87  | 1.44 | .59 | .41 | .78  | .44    | 1-1/16 |
| 12-12 ZHBW | 1210-6-12W         | 3/4       | 1.92 | .87  | 1.52 | .69 | .50 | 1.09 | .63    | 1-1/8  |
| 12-16 ZHBW | 1210-6-16W         | 3/4       | 2.13 | .87  | 1.73 | .75 | .56 | 1.44 | .91    | 1-5/8  |
| 16-4 ZHBW  | 1610-6-4W          | 1         | 1.95 | 1.05 | 1.46 | .44 | .25 | .50  | .19    | 1-3/8  |
| 16-6 ZHBW  | 1610-6-6W          | 1         | 2.05 | 1.05 | 1.56 | .53 | .34 | .63  | .31    | 1-3/8  |
| 16-12 ZHBW | 1610-6-12W         | 1         | 2.20 | 1.05 | 1.71 | .69 | .50 | 1.09 | .66    | 1-3/8  |
| 16-16 ZHBW | 1610-6-16W         | 1         | 2.31 | 1.05 | 1.82 | .75 | .56 | 1.44 | .88    | 1-5/8  |
| 16-20 ZHBW | 1610-6-20W         | 1         | 2.43 | 1.05 | 1.94 | .81 | .63 | 1.75 | .88    | 1-7/8  |
| 20-16 ZHBW | 2000-6-16W         | 1-1/4     | 2.81 | 1.52 | 1.95 | .75 | .56 | 1.44 | .91    | 1-3/4  |
| 20-20 ZHBW | 2000-6-20W         | 1-1/4     | 2.90 | 1.52 | 2.04 | .81 | .63 | 1.75 | 1.09   | 1-7/8  |
| 24-12 ZHBW | 2400-6-12W         | 1-1/2     | 3.15 | 1.77 | 2.09 | .69 | .50 | 1.09 | .66    | 2-1/8  |
| 24-20 ZHBW | 2400-6-20W         | 1-1/2     | 3.27 | 1.77 | 2.21 | .81 | .63 | 1.75 | 1.06   | 2-1/8  |
| 24-24 ZHBW | 2400-6-24W         | 1-1/2     | 3.32 | 1.77 | 2.26 | .86 | .67 | 2.00 | 1.31   | 2-1/8  |
| 32-32 ZHBW | 3200-6-32W         | 2         | 4.40 | 2.47 | 2.93 | .97 | .78 | 2.63 | 1.81   | 2-3/4  |

**NOTE:** A and C dimensions are typical finger-tight.

Dimensions for reference only, subject to change.

For A-LOK® tube fitting double ferrule system replace "B" (ZHBW) with a "L" (ZHLW)

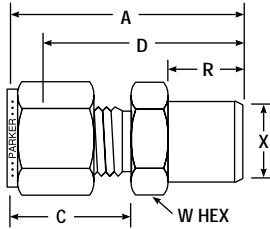
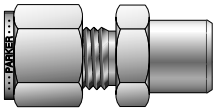
\*Socket Depth

# Weld-lok® To Compression

## ZHBW2

Buttweld connector for fractional pipe

• for CPI™ to pipe buttweld connection



| PART NO.       | INTER-CHANGES WITH | TUBE O.D. | BUTT-WELD PIPE SIZE | A    | C    | D     | R    | X    | BUTT-WELD O.D. | W HEX |
|----------------|--------------------|-----------|---------------------|------|------|-------|------|------|----------------|-------|
| 1-1/8 ZHBW2    | 00-1-2W            | 1/16      | 1/8                 | 1.03 | .43  | .88   | .38  | .41  | 7/16           | 7/16  |
| 2-1/8 ZHBW2    | 200-1-2W           | 1/8       | 1/8                 | 1.20 | .60  | .94   | .38  | .41  | 7/16           | 7/16  |
| 2-1/4 ZHBW2    | 200-1-4W           | 1/8       | 1/4                 | 1.40 | .60  | 1.14  | .56  | .54  | 9/16           | 9/16  |
| 2-1/2 ZHBW2    | 200-1-8W           | 1/8       | 1/2                 | 1.67 | .60  | 1.41  | .75  | .84  | 7/8            | 7/8   |
| 3-1/8 ZHBW2    | 300-1-2W           | 3/16      | 1/8                 | 1.24 | .64  | .97   | .38  | .41  | 7/16           | 7/16  |
| 4-1/8 ZHBW2    | 400-1-2W           | 1/4       | 1/8                 | 1.29 | .70  | 1.00  | .38  | .41  | 1/2            | 1/2   |
| 4-1/4 ZHBW2    | 400-1-4W           | 1/4       | 1/4                 | 1.50 | .70  | 1.20  | .56  | .54  | 5/8            | 5/8   |
| 4-3/8 ZHBW2    | 400-1-6W           | 1/4       | 3/8                 | 1.54 | .70  | 1.25  | .56  | .68  | 3/4            | 3/4   |
| 4-1/2 ZHBW2    | 400-1-8W           | 1/4       | 1/2                 | 1.76 | .70  | 1.47  | .75  | .84  | 7/8            | 7/8   |
| 4-3/4 ZHBW2    | 400-1-12W          | 1/4       | 3/4                 | 1.82 | .70  | 1.53  | .75  | 1.05 | 1-1/8          | 1-1/8 |
| 4-1 ZHBW2      | 400-1-16W          | 1/4       | 1                   | 2.10 | .70  | 1.81  | .94  | 1.32 | 1-3/8          | 1-3/8 |
| 5-1/8 ZHBW2    | 500-1-2W           | 5/16      | 1/8                 | 1.34 | .73  | 1.05  | .38  | .41  | 9/16           | 9/16  |
| 5-1/4 ZHBW2    | 500-1-4W           | 5/16      | 1/4                 | 1.52 | .73  | 1.23  | .56  | .54  | 9/16           | 9/16  |
| 5-1/2 ZHBW2    | 500-1-8W           | 5/16      | 1/2                 | 1.79 | .73  | 1.500 | .75  | .84  | 7/8            | 7/8   |
| 6-1/4 ZHBW2    | 600-1-4W           | 3/8       | 1/4                 | 1.57 | .76  | 1.28  | .56  | .54  | 5/8            | 5/8   |
| 6-3/8 ZHBW2    | 600-1-6W           | 3/8       | 3/8                 | 1.57 | .76  | 1.28  | .56  | .68  | 3/4            | 3/4   |
| 6-1/2 ZHBW2    | 600-1-8W           | 3/8       | 1/2                 | 1.82 | .76  | 1.53  | .75  | .84  | 7/8            | 7/8   |
| 6-3/4 ZHBW2    | 600-1-12W          | 3/8       | 3/4                 | 1.88 | .76  | 1.59  | .75  | 1.05 | 1-1/8          | 1-1/8 |
| 6-1 ZHBW2      | 600-1-16W          | 3/8       | 1                   | 2.17 | .76  | 1.88  | .94  | 1.32 | 1-3/8          | 1-3/8 |
| 6-1-1/2 ZHBW2  | 600-1-24W          | 3/8       | 1-1/2               | 2.39 | .76  | 2.10  | 1.03 | 1.90 | 2              | 2     |
| 6-2 ZHBW2      | 600-1-32W          | 3/8       | 2                   | 2.58 | .76  | 2.29  | 1.06 | 2.38 | 2-1/2          | 2-1/2 |
| 8-1/8 ZHBW2    | 810-1-2W           | 1/2       | 1/8                 | 1.53 | .87  | 1.13  | .38  | .41  | 13/16          | 13/16 |
| 8-1/4 ZHBW2    | 810-1-4W           | 1/2       | 1/4                 | 1.71 | .87  | 1.31  | .56  | .54  | 13/16          | 13/16 |
| 8-3/8 ZHBW2    | 810-1-6W           | 1/2       | 3/8                 | 1.71 | .87  | 1.31  | .56  | .68  | 13/16          | 13/16 |
| 8-1/2 ZHBW2    | 810-1-8W           | 1/2       | 1/2                 | 1.93 | .87  | 1.53  | .75  | .84  | 7/8            | 7/8   |
| 8-3/4 ZHBW2    | 810-1-12W          | 1/2       | 3/4                 | 1.99 | .87  | 1.59  | .75  | 1.05 | 1-1/8          | 1-1/8 |
| 8-1 ZHBW2      | 81-1-16W           | 1/2       | 1                   | 2.28 | .87  | 1.88  | .94  | 1.32 | 1-3/8          | 1-3/8 |
| 8-1-1/2 ZHBW2  | 810-1-24W          | 1/2       | 1-1/2               | 2.50 | .87  | 2.10  | 1.03 | 1.90 | 2              | 2     |
| 10-1/4 ZHBW2   | 1010-1-4W          | 5/8       | 1/4                 | 1.74 | .87  | 1.34  | .56  | .54  | 15/16          | 15/16 |
| 10-3/8 ZHBW2   | 1010-1-6W          | 5/8       | 3/8                 | 1.74 | .87  | 1.34  | .56  | .67  | 15/16          | 15/16 |
| 10-1/2 ZHBW2   | 1010-1-8W          | 5/8       | 1/2                 | 1.93 | .87  | 1.53  | .75  | .84  | 15/16          | 15/16 |
| 10-3/4 ZHBW2   | 1010-1-12W         | 5/8       | 3/4                 | 1.99 | .87  | 1.59  | .75  | 1.05 | 1-1/8          | 1-1/8 |
| 12-3/8 ZHBW2   | 1210-1-6W          | 3/4       | 3/8                 | 1.81 | .87  | 1.41  | .56  | .67  | 1-1/8          | 1-1/8 |
| 12-1/2 ZHBW2   | 1210-1-8W          | 3/4       | 1/2                 | 1.99 | .87  | 1.59  | .75  | .84  | 1-1/8          | 1-1/8 |
| 12-3/4 ZHBW2   | 1210-1-12W         | 3/4       | 3/4                 | 1.99 | .87  | 1.59  | .75  | 1.05 | 1-1/8          | 1-1/8 |
| 12-1 ZHBW2     | 1210-1-16W         | 3/4       | 1                   | 2.28 | .87  | 1.88  | .94  | 1.32 | 1-3/8          | 1-3/8 |
| 16-1/2 ZHBW2   | 1610-1-8W          | 1         | 1/2                 | 2.18 | 1.05 | 1.78  | .75  | .84  | 1-3/8          | 1-3/8 |
| 16-3/4 ZHBW2   | 1610-1-12W         | 1         | 3/4                 | 2.27 | 1.05 | 1.78  | .75  | 1.05 | 1-3/8          | 1-3/8 |
| 16-1 ZHBW2     | 1610-1-16W         | 1         | 1                   | 2.46 | 1.05 | 1.97  | .94  | 1.32 | 1-3/8          | 1-3/8 |
| 16-1-1/4 ZHBW2 | 1610-1-20W         | 1         | 1-1/4               | 2.56 | 1.05 | 2.07  | .94  | 1.66 | 1-3/4          | 1-3/4 |
| 16-1-1/2 ZHBW2 | 1610-1-24W         | 1         | 1-1/2               | 2.68 | 1.05 | 2.19  | 1.03 | 1.90 | 2              | 2     |
| 20-1 ZHBW2     | 2000-1-16W         | 1-1/4     | 1                   | 3.06 | 1.52 | 2.20  | .94  | 1.32 | 1-3/4          | 1-3/4 |
| 20-1-1/4 ZHBW2 | 2000-1-20W         | 1-1/4     | 1-1/4               | 3.03 | 1.52 | 2.17  | .94  | 1.66 | 1-3/4          | 1-3/4 |
| 20-1-1/2 ZHBW2 | 2000-1-24W         | 1-1/4     | 1-1/2               | 3.16 | 1.52 | 2.30  | 1.03 | 1.90 | 2              | 2     |
| 24-1 ZHBW2     | 2400-1-16W         | 1-1/2     | 1                   | 3.50 | 1.77 | 2.44  | .94  | 1.32 | 2-1/8          | 2-1/8 |
| 24-1-1/4 ZHBW2 | 2400-1-20W         | 1-1/2     | 1-1/4               | 3.36 | 1.77 | 2.30  | .94  | 1.66 | 2-1/8          | 2-1/8 |
| 24-1-1/2 ZHBW2 | 2400-1-24W         | 1-1/2     | 1-1/2               | 3.50 | 1.77 | 2.44  | 1.03 | 1.90 | 2-1/8          | 2-1/8 |
| 32-2 ZHBW2     | 3200-1-32W         | 2         | 2                   | 4.47 | 2.47 | 3.00  | 1.06 | 2.38 | 2-3/4          | 2-3/4 |

**NOTE:** A and C dimensions are typical finger-tight.

Dimensions for reference only, subject to change.

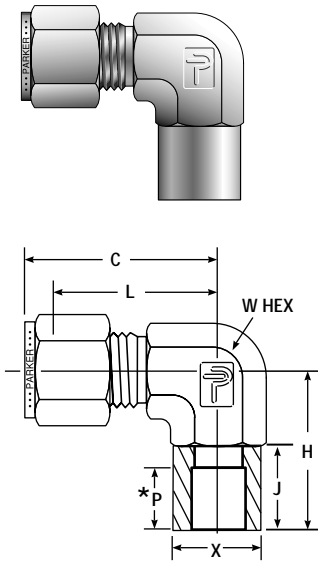
Pipe Buttweld end will conform to Schedule 80 unless otherwise noted.

For A-LOK® tube fitting double ferrule system replace "B" (ZHBW2) with a "L" (ZHLW2)

## ZEBW

### For fractional tube

- for CPI™ to tubing socket weld connection



| PART NO.   | INTERCHANGES WITH | TUBE O.D. | C    | L    | H    | J   | *P  | X DIA. | W HEX  |
|------------|-------------------|-----------|------|------|------|-----|-----|--------|--------|
| 2-2 ZEBW   | 200-9-2W          | 1/8       | .93  | .70  | .70  | .34 | .16 | .38    | 1/2    |
| 3-3 ZEBW   | 300-9-3W          | 3/16      | 1.01 | .74  | .75  | .39 | .20 | .44    | 1/2    |
| 4-4 ZEBW   | 400-9-4W          | 1/4       | 1.07 | .78  | .78  | .44 | .25 | .50    | 9/16   |
| 6-6 ZEBW   | 600-9-6W          | 3/8       | 1.31 | 1.02 | 1.08 | .53 | .34 | .63    | 3/4    |
| 6-12 ZEBW  | 600-9-12W         | 3/8       | 1.46 | 1.17 | 1.39 | .69 | .50 | 1.09   | 1-1/16 |
| 6-16 ZEBW  | 600-9-16W         | 3/8       | 1.84 | 1.55 | 1.84 | .75 | .56 | 1.44   | 1-5/8  |
| 8-4 ZEBW   | 800-9-4W          | 1/2       | 1.42 | 1.02 | .99  | .44 | .25 | .50    | 13/16  |
| 8-8 ZEBW   | 800-9-8W          | 1/2       | 1.42 | 1.02 | 1.14 | .59 | .41 | .78    | 13/16  |
| 8-10 ZEBW  | 800-9-10W         | 1/2       | 1.57 | 1.17 | 1.36 | .66 | .47 | .94    | 1-1/16 |
| 8-12 ZEBW  | 800-9-12W         | 1/2       | 1.57 | 1.17 | 1.34 | .69 | .50 | 1.09   | 1-1/16 |
| 8-16 ZEBW  | 800-9-16W         | 1/2       | 1.95 | 1.55 | 1.84 | .75 | .56 | 1.44   | 1-5/8  |
| 10-6 ZEBW  | 1010-9-6W         | 5/8       | 1.50 | 1.10 | 1.16 | .53 | .34 | .63    | 15/16  |
| 10-8 ZEBW  | 1010-9-8W         | 5/8       | 1.50 | 1.10 | 1.22 | .59 | .41 | .78    | 15/16  |
| 10-10 ZEBW | 1010-9-10W        | 5/8       | 1.57 | 1.17 | 1.36 | .66 | .47 | .94    | 1-1/16 |
| 10-16 ZEBW | 1010-9-16W        | 5/8       | 1.95 | 1.55 | 1.84 | .75 | .56 | 1.44   | 1-5/8  |
| 12-12 ZEBW | 1210-9-12W        | 3/4       | 1.57 | 1.17 | 1.39 | .69 | .50 | 1.09   | 1-1/16 |
| 14-12 ZEBW | 1410-9-12W        | 7/8       | 1.76 | 1.36 | 1.58 | .69 | .50 | 1.09   | 1-3/8  |
| 16-14 ZEBW | 1610-9-14W        | 1         | 1.94 | 1.45 | 1.58 | .69 | .50 | 1.31   | 1-3/8  |
| 16-16 ZEBW | 1610-9-16W        | 1         | 2.14 | 1.65 | 1.84 | .75 | .56 | 1.44   | 1-5/8  |

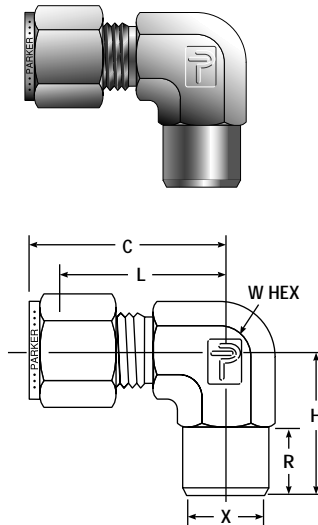
**NOTE:** C dimension is typical finger-tight. Dimensions for reference only, subject to change. For A-LOK® tube fitting double ferrule system replace "B" (ZEBW) with a "L" (ZHLW)

\*Socket Depth

## ZEBW2

### Buttweld elbow for fractional pipe

- for CPI™ to pipe connection



| PART NO.       | INTERCHANGES WITH | TUBE O.D. | BUTT-WELD PIPE SIZE | C    | H    | L    | R    | X BUTT-WELD O.D. | W HEX  |
|----------------|-------------------|-----------|---------------------|------|------|------|------|------------------|--------|
| 2-1/8 ZEBW2    | 200-2-2W          | 1/8       | 1/8                 | .93  | .70  | .67  | .38  | .41              | 7/16   |
| 3-1/8 ZEBW2    | 300-2-2W          | 3/16      | 1/8                 | 1.01 | .74  | .74  | .38  | .41              | 1/2    |
| 4-1/8 ZEBW2    | 400-2-2W          | 1/4       | 1/8                 | 1.06 | .74  | .77  | .38  | .41              | 1/2    |
| 4-1/4 ZEBW2    | 400-2-4W          | 1/4       | 1/4                 | 1.10 | .97  | .81  | .56  | .54              | 9/16   |
| 4-3/4 ZEBW2    | 400-2-12W         | 1/4       | 3/4                 | 1.40 | 1.45 | 1.11 | .75  | 1.05             | 1-1/16 |
| 6-1/4 ZEBW2    | 600-2-4W          | 3/8       | 1/4                 | 1.20 | 1.00 | .91  | .56  | .54              | 5/8    |
| 6-3/8 ZEBW2    | 600-2-6W          | 3/8       | 3/8                 | 1.31 | 1.11 | 1.02 | .56  | .68              | 13/16  |
| 6-1/2 ZEBW2    | 600-2-8W          | 3/8       | 1/2                 | 1.31 | 1.30 | 1.02 | .75  | .84              | 7/8    |
| 6-3/4 ZEBW2    | 600-2-12W         | 3/8       | 3/4                 | 1.46 | 1.45 | 1.17 | .75  | 1.05             | 1-1/16 |
| 6-1 ZEBW2      | 600-2-16W         | 3/8       | 1                   | 1.65 | 1.83 | 1.36 | .94  | 1.32             | 1-3/8  |
| 8-1/4 ZEBW2    | 810-2-4W          | 1/2       | 1/4                 | 1.42 | 1.11 | 1.02 | .56  | .54              | 13/16  |
| 8-3/8 ZEBW2    | 810-2-6W          | 1/2       | 3/8                 | 1.42 | 1.11 | 1.02 | .56  | .68              | 13/16  |
| 8-1/2 ZEBW2    | 810-2-8W          | 1/2       | 1/2                 | 1.42 | 1.30 | 1.02 | .75  | .84              | 7/8    |
| 8-3/4 ZEBW2    | 810-2-12W         | 1/2       | 3/4                 | 1.57 | 1.45 | 1.17 | .75  | 1.05             | 1-1/16 |
| 8-1 ZEBW2      | 810-W-16W         | 1/2       | 1                   | 1.76 | 1.86 | 1.36 | .94  | 1.32             | 1-3/8  |
| 10-1/2 ZEBW2   | 1010-2-8W         | 5/8       | 1/2                 | 1.50 | 1.39 | 1.10 | .75  | .84              | 15/16  |
| 12-1/2 ZEBW2   | 1210-2-8W         | 3/4       | 1/2                 | 1.66 | 1.45 | 1.26 | .75  | .84              | 1-1/16 |
| 12-3/4 ZEBW2   | 1210-2-12W        | 3/4       | 3/4                 | 1.57 | 1.45 | 1.17 | .75  | 1.05             | 1-1/16 |
| 14-3/4 ZEBW2   | 1410-2-12W        | 7/8       | 3/4                 | 1.78 | 1.64 | 1.36 | .75  | 1.05             | 1-3/8  |
| 14-1 ZEBW2     | 1410-W-16W        | 7/8       | 1                   | 1.78 | 1.83 | 1.36 | .94  | 1.32             | 1-3/8  |
| 16-1/2 ZEBW2   | 1610-2-8W         | 1         | 1/2                 | 1.94 | 1.64 | 1.45 | .75  | .84              | 1-3/8  |
| 16-3/4 ZEBW2   | 1610-2-12W        | 1         | 3/4                 | 1.94 | 1.64 | 1.45 | .75  | 1.05             | 1-3/8  |
| 16-1 ZEBW2     | 1610-2-16W        | 1         | 1                   | 1.94 | 1.83 | 1.45 | .94  | 1.32             | 1-3/8  |
| 16-1-1/4 ZEBW2 | 1610-2-20W        | 1         | 1-1/4               | 2.14 | 1.88 | 1.65 | .94  | 1.66             | 1-5/8  |
| 20-1-1/4 ZEBW2 | 2000-2-20W        | 1-1/4     | 1-1/4               | 2.61 | 2.02 | 1.75 | .94  | 1.66             | 1-5/8  |
| 24-1-1/2 ZEBW2 | 2400-2-24W        | 1-1/2     | 1-1/2               | 3.06 | 2.38 | 2.00 | 1.03 | 1.90             | 1-7/8  |

**NOTE:** C dimension is typical finger-tight. Dimensions for reference only, subject to change. Pipe buttweld end will conform to Schedule 80 unless otherwise noted.

For A-LOK® tube fitting double ferrule system replace "B" (ZEBW2) with a "L" (ZELW2)





# Offer of Sale

The items described in this document and other documents or descriptions provided by Parker Hannifin Corporation, its subsidiaries and its authorized distributors are hereby offered for sale at prices to be established by Parker Hannifin Corporation, its subsidiaries and its authorized distributors. This offer and its acceptance by any customer ("Buyer") shall be governed by all of the following Terms and Conditions. Buyer's order for any such items, when communicated to Parker Hannifin Corporation, its subsidiary or an authorized distributor ("Seller") verbally or in writing, shall constitute acceptance of this offer.

**1. Terms and Conditions of Sale:** All descriptions, quotations, proposals, offers, acknowledgments, acceptances and sales of Seller's products are subject to and shall be governed exclusively by the terms and conditions stated herein. Buyer's acceptance of any offer to sell is limited to these terms and conditions. Any terms or conditions in addition to, or inconsistent with those stated herein, proposed by Buyer in any acceptance of an offer by Seller, are hereby objected to. No such additional, different or inconsistent terms and conditions shall become part of the contract between Buyer and Seller unless expressly accepted in writing by Seller. Seller's acceptance of any offer to purchase by Buyer is expressly conditional upon Buyer's assent to all the terms and conditions stated herein, including any terms in addition to, or inconsistent with those contained in Buyer's offer. Acceptance of Seller's products shall in all events constitute such assent.

**2. Payment:** Payment shall be made by Buyer net 30 days from the date of delivery of the items purchased hereunder. Amounts not timely paid shall bear interest at the maximum rate permitted by law for each month or portion thereof that the Buyer is late in making payment. Any claims by Buyer for omissions or shortages in a shipment shall be waived unless Seller receives notice thereof within 30 days after Buyer's receipt of the shipment.

**3. Delivery:** Unless otherwise provided on the face hereof, delivery shall be made F.O.B. Seller's plant. Regardless of the method of delivery, however, risk of loss shall pass to Buyer upon Seller's delivery to a carrier. Any delivery dates shown are approximate only and Seller shall have no liability for any delays in delivery.

**4. Warranty:** Seller warrants that items sold hereunder shall be free from defects in material or workmanship. **THIS WARRANTY COMPRISES THE SOLE AND ENTIRE WARRANTY PERTAINING TO ITEMS PROVIDED HEREUNDER. SELLER MAKES NO OTHER WARRANTY, GUARANTEE, OR REPRESENTATION OF ANY KIND WHATSOEVER. ALL OTHER WARRANTIES, INCLUDING BUT NOT LIMITED TO, MERCHANTABILITY AND FITNESS FOR PURPOSE, WHETHER EXPRESS, IMPLIED, OR ARISING BY OPERATION OF LAW, TRADE USAGE, OR COURSE OF DEALING ARE HEREBY DISCLAIMED.**

**NOTWITHSTANDING THE FOREGOING, THERE ARE NO WARRANTIES WHATSOEVER ON ITEMS BUILT OR ACQUIRED WHOLLY OR PARTIALLY, TO BUYER'S DESIGNS OR SPECIFICATIONS.**

**5. Limitation Of Remedy: SELLER'S LIABILITY ARISING FROM OR IN ANY WAY CONNECTED WITH THE ITEMS SOLD OR THIS CONTRACT SHALL BE LIMITED EXCLUSIVELY TO REPAIR OR REPLACEMENT OF THE ITEMS SOLD, AT SELLER'S SOLE OPTION. IN NO EVENT SHALL SELLER BE LIABLE FOR ANY INCIDENTAL, CONSEQUENTIAL OR SPECIAL DAMAGES OF ANY KIND OR NATURE WHATSOEVER, INCLUDING BUT NOT LIMITED TO LOST PROFITS ARISING FROM OR IN ANY WAY CONNECTED WITH THIS AGREEMENT OR ITEMS SOLD HEREUNDER, WHETHER ALLEGED TO ARISE FROM BREACH OF CONTRACT, EXPRESS OR IMPLIED WARRANTY, OR IN TORT, INCLUDING WITHOUT LIMITATION, NEGLIGENCE, FAILURE TO WARN OR STRICT LIABILITY.**

**6. Changes, Reschedules and Cancellations:** Buyer may request to modify the designs or specifications for the items sold hereunder as well as the quantities and delivery dates thereof, or may request to cancel all or part of this order, however, no such requested modification or cancellation shall become part of the contract between Buyer and Seller unless accepted by Seller in a written amendment to this Agreement. Acceptance of any such requested modification or cancellation shall be at Seller's discretion, and shall be upon such terms and conditions as Seller may require.

**7. Special Tooling:** A tooling charge may be imposed for any special tooling, including without limitation, dies, fixtures, molds and patterns, acquired to manufacture items sold pursuant to this contract. Such special tooling shall be and remain Seller's property notwithstanding payment of any charges by Buyer. In no event will Buyer acquire any interest in apparatus belonging to Seller which is utilized in the manufacture of the items sold hereunder, even if such apparatus has been specially converted or adapted for such manufacture and not withstanding any charges paid by Buyer. Unless otherwise agreed, Seller shall have the right to alter, discard or otherwise dispose of any special tooling or other property in its sole discretion at any time.

**8. Buyer's Property:** Any designs, tools, patterns, materials, drawings, confidential information or equipment furnished by Buyer or any other items which become Buyer's property, may be considered obsolete and may be destroyed by Seller after two (2) consecutive years have elapsed without Buyer placing an order for the items which are manufactured using such property, Seller shall not be responsible for any loss or damage to such property while it is in Seller's possession or control.

**9. Taxes:** Unless otherwise indicated on the face hereof, all prices and charges are exclusive of excise, sales, use, property, occupational or like taxes which may be imposed by any taxing authority upon the manufacture, sale or delivery of the items sold hereunder. If any such taxes must be paid by Seller or if Seller is liable for the collection of such tax, the amount thereof shall be in addition to the amounts for the items sold. Buyer agrees to pay all such taxes or to reimburse Seller therefore upon receipt of its invoice. If Buyer claims exemption from any sales, use or other tax imposed by any taxing authority, Buyer shall save Seller harmless from and against any such tax, together with any interest or penalties thereon which may be assessed if the items are held to be taxable.

**10. Indemnity For Infringement of Intellectual Property Rights:** Seller shall have no liability for infringement of any patents, trademarks, copyrights, trade dress, trade secrets or similar rights except as provided in this Part 10. Seller will defend and indemnify Buyer against allegations of infringement of U.S. Patents, U.S. Trademarks, copyrights, trade dress and trade secrets (hereinafter 'Intellectual Property Rights'). Seller will defend at its expense and will pay the cost of any settlement or damages awarded in an action brought against Buyer based on an allegation that an item sold pursuant to this contract infringes the Intellectual Property Rights of a third party. Seller's obligation to defend and indemnify Buyer is contingent on Buyer notifying Seller within ten (10) days after Buyer becomes aware of such allegations of infringement, and Seller having sole control over the defense of any allegations or actions including all negotiations for settlement or compromise. If an item sold hereunder is subject to a claim that it infringes the Intellectual Property Rights of a third party, Seller may, at its sole expense and option, procure for Buyer the right to continue using said item, replace or modify said item so as to make it noninfringing, or offer to accept return of said item and return the purchase price less a reasonable allowance for depreciation. Notwithstanding the foregoing, Seller shall have no liability for claims of infringement based on information provided by Buyer, or directed to items delivered hereunder for which the designs are specified in whole or part by Buyer, or infringements resulting from the modification, combination or use in a system of any item sold hereunder. The foregoing provisions of this Part 10 shall constitute Seller's sole and exclusive liability and Buyer's sole and exclusive remedy for infringement of Intellectual Property Rights.

If a claim is based on information provided by Buyer or if the design for an item delivered hereunder is specified in whole or in part by Buyer, Buyer shall defend and indemnify Seller for all costs, expenses or judgments resulting from any claim that such item infringes any patent, trademark, copyright, trade dress, trade secret or any similar right.

**11. Force Majeure:** Seller does not assume the risk of and shall not be liable for delay or failure to perform any of Seller's obligations by reason of circumstances beyond the reasonable control of Seller (hereinafter 'Events of Force Majeure'). Events of Force Majeure shall include without limitation, accidents, acts of God, strikes or labor disputes, acts, laws, rules or regulations of any government or government agency, fires, floods, delays or failures in delivery of carriers or suppliers, shortages of materials and any other cause beyond Seller's control.

**12. Entire Agreement/Governing Law:** The terms and conditions set forth herein, together with any amendments, modifications and any different terms or conditions expressly accepted by Seller in writing, shall constitute the entire Agreement concerning the items sold, and there are no oral or other representations or agreements which pertain thereto. This Agreement shall be governed in all respects by the law of the State of Ohio. No actions arising out of the sale of the items sold hereunder or this Agreement may be brought by either party more than two (2) years after the cause of action accrues.

11/98-P



**Parker Hannifin Corporation**  
6035 Parkland Blvd.  
Cleveland, Ohio 44124-4141  
Telephone: (216) 896-3000  
Fax: (216) 896-4000  
www.parker.com

## Parker Hannifin Corporation

### About Parker Hannifin Corporation

Parker Hannifin is a leading global motion-control company dedicated to delivering premier customer service. A Fortune 500 corporation listed on the New York Stock Exchange (PH), our components and systems comprise over 1,400 product lines that control motion in some 1,000 industrial and aerospace markets. Parker is the only manufacturer to offer its customers a choice of hydraulic, pneumatic, and electromechanical motion-control solutions. Our company has the largest distribution network in its field, with over 7,500 distributors serving nearly 400,000 customers worldwide.

### Parker's Charter

To be a leading worldwide manufacturer of components and systems for the builders and users of durable goods. More specifically, we will design, market and manufacture products controlling motion, flow and pressure. We will achieve profitable growth through premier customer service.

### Product Information

North American customers seeking product information, the location of a nearby distributor, or repair services will receive prompt attention by calling the Parker Product Information Center at our toll-free number: 1-800-C-PARKER (1-800-272-7537). In Europe, call 00800-C-PARKER-H (00800-2727-5374).

The Aerospace Group is a leader in the development, design, manufacture and servicing of control systems and components for aerospace and related high-technology markets, while achieving growth through premier customer service.



The Climate & Industrial Controls Group designs, manufactures and markets system-control and fluid-handling components and systems to refrigeration, air-conditioning and industrial customers worldwide.

The Fluid Connectors Group designs, manufactures and markets rigid and flexible connectors, and associated products used in pneumatic and fluid systems.



The Seal Group designs, manufactures and distributes industrial and commercial sealing devices and related products by providing superior quality and total customer satisfaction.

The Hydraulics Group designs, produces and markets a full spectrum of hydraulic components and systems to builders and users of industrial and mobile machinery and equipment.



The Filtration Group designs, manufactures and markets quality filtration and clarification products, providing customers with the best value, quality, technical support, and global availability.

The Automation Group is a leading supplier of pneumatic and electromechanical components and systems to automation customers worldwide.



The Instrumentation Group is a global leader in the design, manufacture and distribution of high-quality critical flow components for worldwide process instrumentation, ultra-high-purity, medical and analytical applications.



**Parker Hannifin Corporation**

Instrumentation Connectors Division  
P.O. Box 400004-1504  
Huntsville, AL 35815-1504  
USA  
Phone: (256) 881-2040  
Fax: (256) 881-5730  
[www.parker.com/ICD](http://www.parker.com/ICD)

**Parker Hannifin plc**

Instrumentation Products Division  
Riverside Road  
Pottington Industrial Estate  
Barnstaple, Devon EX31 1NP  
England  
Phone: (44) (1271) 313131  
Fax: (44) (1271) 373636  
[www.parker.com/instrumentation](http://www.parker.com/instrumentation)