

PTFE HOSE

Introduction

Parker reinforced PTFE hose is manufactured with a high-performance PTFE core material. Our PTFE hose provide fluid conveyance solutions for a wide range of applications across many markets. Parker PTFE hose offer excellent chemical resistance and is virtually inert to all chemical. Many other benefits of Parker PTFE hose include:

BENEFITS:

- Extreme high and low temperature range
- Low friction minimizes pressure drops and deposits
- Exceptional chemical resistance
- Stainless steel braid reinforcement is cleaned to reduce hydrocarbon content
- High purity non-contaminating material for pure system applications
- Flexibility allows motion, vibration dampening and easier routing & installation

How to Order

P	919	TU	AL	08	08	08	C -	36
TYPE OF CONNECTION	HOSE STYLE	1ST END CONNECTION	2ND END CONNECTION	1ST END DASH SIZE	2ND END DASH SIZE	HOSE I.D. DASH SIZE	FITTING MATERIAL	OVERALL ASSEMBLY LENGTH (INCHES)
P=Permanent Crimp	919 919B 919J 929 929B	01 = Male NPT 03 = Male JIC 37° 06 = Female SAE (JIC) 37° Swivel AL = A-LOK® Compression P6 = CPI™ Compression (nut & ferrule) TU = Universal Tube Stub HV = Male Vacuseal VH = Female Vacuseal		02=1/8" 04=1/4" 06=3/8" 08=1/2" 12=3/4" 16=1"		04=3/16" 06=5/16" 08=13/32" 12=5/8" 16=7/8"	C=Stainless	Overall length is expressed in inches measured from extreme end to end. Except elbow fittings which are measured from centerline or the seat.

Other End Connections and styles available. See Parflex 4660 catalog at www.Parker.com for additional details.

Assemblies are to be measured extreme end to end. Exception:

1. Face seal type fittings shall be measured from sealing to face.
2. Where elbow fittings are used, measurement shall be to the centerline of the sealing surface of the elbow end.
3. "A-LOK®" and "CPI™" fittings are measured from tube stops.

919 PTFE HOSE

PTFE Hose



HOSE SERIES - DASH SIZE	VACUUM RATING	HOSE I.D.		MAX. HOSE O.D.		WALL THICKNESS		MAXIMUM WORKING PRESSURE		MINIMUM BEND RADIUS		WEIGHT		CRIMP DIE PART NO.
		INCHES/HG	INCHES	MM	INCHES	MM	INCHES	MM	PSI	MPA	INCHES	MM	LBS/FT	
919-4	28	3/16	5	5/16	8	.030	.762	3000	20.7	2.0	51	0.056	0.09	80C-T04N
919-5	28	1/4	6	3/8	10	.030	.762	3000	20.7	3.0	76	0.086	0.13	80C-T05N
919-6	28	5/16	8	7/16	11	.030	.762	2500	17.2	4.0	102	0.103	0.15	80C-T06N
919-8	28	13/32	10.5	17/32	14	.030	.762	2000	13.8	5.0	127	0.126	0.19	80C-T08N
919-10	28	1/2	12.5	5/8	16	.030	.762	1500	10.3	6.5	165	0.149	0.22	80C-T10N
919-12	12	5/18	16	3/4	19	.030	.762	1200	8.3	7.5	191	0.186	0.28	80C-T12N
919-16	14	7/8	22	1-1/32	26	.035	.889	1000	6.9	9.0	229	0.268	0.4	80C-T16N

Construction: Smooth bore natural PTFE core tube with a type 304 stainless steel braided wire reinforcement.

Typical applications: Instrumentation lines, analyzer sampling lines and for areas that require tight routing.

Temperature range: -100°F to +450°F (-73°C to +232°C)

919B PTFE Hose

Static-Dissipative Hose



HOSE SERIES - DASH SIZE	VACUUM RATING	HOSE I.D.		MAX. HOSE O.D.		WALL THICKNESS		MAXIMUM WORKING PRESSURE		MINIMUM BEND RADIUS		WEIGHT		CRIMP DIE PART NO.
		INCHES/HG	INCHES	MM	INCHES	MM	INCHES	MM	PSI	MPA	INCHES	MM	LBS/FT	
919B-5	28	1/4	6	3/8	10	.030	.762	3000	20.7	3.0	76	0.086	0.13	80C-T05N
919B-6	28	5/16	8	7/16	11	.030	.762	2500	17.2	4.0	102	0.103	0.15	80C-T06N
919B-8	28	13/32	10.5	17/32	14	.030	.762	2000	13.8	5.0	127	0.126	0.19	80C-T08N

Construction: Smooth bore black PTFE core tube with a type 304 stainless steel braided wire reinforcement.

Typical applications: Static-Dissipative PTFE black core tube. Transfer line for most chemicals, hot oils, fuel lines, coolant and steam transfer. Compressed air and gases. Adhesive dispensing, paints and coating materials.

Temperature range: -100°F to +450°F (-73°C to +232°C)

919J PTFE Hose

Silicone Jacketed PTFE Hose



HOSE SERIES - DASH SIZE	VACUUM RATING	HOSE I.D.		MAX. HOSE O.D.		WALL THICKNESS		MAXIMUM WORKING PRESSURE		MINIMUM BEND RADIUS		WEIGHT		CRIMP DIE PART NO.
		INCHES/HG	INCHES	MM	INCHES	MM	INCHES	MM	PSI	MPA	INCHES	MM	LBS/FT	
919J-4-Red	28	3/16	5	0.45	11	.030	.762	3000	20.7	2.0	51	0.124	0.19	80C-T04J
919J-6-Red	28	5/16	8	0.58	15	.030	.762	2500	17.2	4.0	102	0.165	0.25	80C-T06J
919J-8-Red	28	13/32	10.5	0.68	17	.030	.762	2000	13.8	5.0	127	0.202	0.3	80C-T08J
919J-10-Red	28	1/2	12.5	0.78	20	.030	.762	1500	10.3	6.5	165	0.236	0.35	80C-T10J
919J-12-Red	12	5/18	16	0.91	23	.030	.762	1200	8.3	7.5	191	0.291	0.43	80C-T12J

Construction: Smooth bore natural PTFE core tube with a type 304 stainless steel braided wire reinforcement and a red extruded silicone jacket.

Typical applications: Transfer lines for most chemicals, coolant lines, adhesive dispensing, compressed air and gases. Areas where a protective cover is required to prevent contamination off of the braided hose. Areas where stainless wire needs protected from fraying. Silicone cover is red and rated for temperatures 450°F and is steam cleanable.

Temperature range: -100°F to +450°F (-73°C to +232°C)

929 PTFE Hose

Heavy Wall Low Permeation Hose



HOSE SERIES - DASH SIZE	VACUUM RATING	HOSE I.D.		MAX. HOSE O.D.		WALL THICKNESS		MAXIMUM WORKING PRESSURE		MINIMUM BEND RADIUS		WEIGHT		CRIMP DIE PART NO.
		INCHES/HG	INCHES	MM	INCHES	MM	INCHES	MM	PSI	MPA	INCHES	MM	LBS/FT	
929-4	28	3/16	5	5/16	8	.040	1.02	3000	20.7	2.0	51	0.06	0.09	80C-T04N
929-6	28	5/16	8	7/16	11	.040	1.02	2500	17.2	4.0	102	0.13	0.15	80C-T06N
929-8	28	13/32	10.5	9/16	14	.042	1.07	2000	13.8	5.0	127	0.126	0.19	80C-T08N
929-12	12	5/18	16	3/4	19	.048	1.22	1200	8.3	7.5	191	0.186	0.28	80C-T12N
929-16	14	7/8	22	1-1/8	26	.048	1.22	1250	6.9	9.0	229	0.268	0.4	80C-T16H

Construction: Smooth bore natural PTFE core tube with a type 304 stainless steel braided wire reinforcement.

Typical applications: Instrumentation lines, analyzer sampling lines and for areas that require tight routing.

Temperature range: -100°F to +450°F (-73°C to +232°C)

PTFE FITTINGS

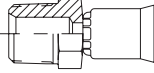
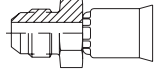
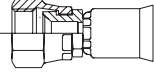
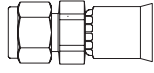
END CONNECTION STYLE	919/929 HOSE STAINLESS FITTING NUMBER	HOSE DASH SIZE
(01) Male Taper Pipe Rigid 	10191N-4-4C	-4
	10191N-6-6C	-6
	10191N-8-8C	-8
	10191N-12-12C	-12
	10191N-16-16C	-16
	10191N-20-20C	-20
(03) Male (JIC) 37° 	10391N-4-4C	-4
	10391N-6-6C	-6
	10391N-8-8C	-8
	10391N-16-16C	-16
(06) Female (JIC) 37° Swivel 	10691N-4-4C	-4
	10691N-6-6C	-6
	10691N-16-16C	-16
	10691N-20-20C	-20
(AL) A-LOK® Compression 	1AL91N-4-4C	-4
	1AL91N-6-6C	-6
	1AL91N-8-8C	-8
	1AL91N-12-12C	-12
	1AL91N-16-16C	-16

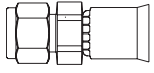
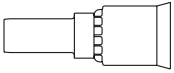
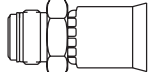
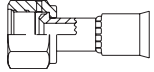
END CONNECTION STYLE	919/929 HOSE STAINLESS FITTING NUMBER	HOSE DASH SIZE
(P6) CPI™ Compression (Nut & Ferrule) 	1P691N-4-4C	-4
	1P691N-6-6C	-6
	1P691N-8-8C	-8
	1P691N-12-12C	-12
	1P691N-16-16C	-16
(TU) Tube Stub 	1TU91N-4-4C	-4
	1TU91N-6-6C	-6
	1TU91N-8-8C	-8
	1TU91N-16-16C	-16
	1TU91N-20-20C	-20
(HV) Male VacuSeal 	1HV91N-4-4C	-4
	1HV91N-6-6C	-6
	1HV91N-8-8C	-8
(VH) Female VacuSeal 	1VH91N-4-4C	-4
	1VH91N-6-6C	-6
	1VH91N-8-8C	-8

PTFE ACCESSORIES

HOSE	DASH SIZE	MAX. O.D.	INTERNAL FLAT SPRING	FIRE SLEEVE
919/929	-4	0.32	-	
	5	0.40	-	
	-6	0.46	-	FS-F-8
	8	0.56	2613-13CR	FS-F-10
	-10	0.66	2613-16CR	FS-F-12
	-12	0.79	2613-20CR	FS-F-14
	-16	1.05	2613-28CR	FS-F-20
	-20	1.32	2613-37CR	FS-F-24

Other hose style accessories can be found by visiting www.Parker.com



Fire Sleeves & Flat Springs

THERMOPLASTIC HOSE

Introduction

Parflex reinforced thermoplastic hose has the industry's highest level of abrasion resistance, outlasting rubber hose in lab tests by as much as 10:1. Hoses are available in long lengths, reducing short hose lengths. Parflex hoses are lighter in weight than comparably sized rubber hoses, in some cases up to 40% lighter. UV resistant jacket, tight bend radius. Other benefits include:

BENEFITS:

- Long shelf life, thermoplastic hoses do not continuously cure.
- Easy to cut and couple.
- UV resistant
- Low volumetric expansion, less energy loss and faster reaction times.
- Clean core tubes reduce the possible contamination of hydraulic systems
- Tight bend radius.

How to Order

520N	TU	AL	08	08	08	C -	36
HOSE STYLE	1ST END CONNECTION	2ND END CONNECTION	1ST CONNECTION DASH SIZE	2ND CONNECTION DASH SIZE	HOSE I.D. DASH SIZE	FITTING MATERIAL	OVERALL ASSEMBLY LENGTH (INCHES)
520N 540P 540N 518C 580N	01 = Male NPT 03 = Male JIC 37° 06 = Female SAE (JIC) 37° Swivel AL = A-LOK® Compression P6 = CPI™ Compression (nut & ferrule) TU = Universal Tube Stub		02=1/8" 04=1/4" 06=3/8" 08=1/2" 12=3/4" 16=1"		04=1/4" 06=3/8" 08=1/2" 12=3/4" 16=1"	C=Stainless	Overall length is expressed in inches measured from extreme end to end. Except elbow fittings which are measured from centerline or the seat.

How to order part derivation is applicable to all hose assemblies in this catalog.

520N

General Hydraulic Hose



HOSE SERIES - DASH SIZE	VACUUM RATING	HOSE I.D.		MAX. HOSE O.D.		MAXIMUM WORKING PRESSURE		MINIMUM BEND RADIUS		WEIGHT		CRIMP DIE PART NO.
		INCHES	MM	INCHES	MM	PSI	MPA	INCHES	MM	LBS/FT	KG/M	
520N-4	28	1/4"	6	0.51	13	5000	34.5	2.0	51	0.06	0.09	80C-P04
520N-6	28	3/8"	10	0.65	16	4000	27.6	2.5	64	0.08	0.12	80C-P06
520N-8	28	1/2"	13	0.81	21	3500	24.1	4.0	102	0.13	0.19	80C-P08

Construction: Nylon Core Tube, Aramid Fiber Reinforcement, Black Perforated Urethane Jacket. Meets or exceeds SAE 100R8 performance.

Typical applications: Hydraulic and pneumatic circuits and systems. Ideal in hot water applications.

Temperature range: -40°F to +212°F (-40°C to +100°C)

Fittings: Use 55 series only.

For additional information about Parflex hose, including information about construction, typical applications and installation, contact your authorized Parker Instrumentation Distributor.

540P

Specialty Water Hose



HOSE SERIES - DASH SIZE	VACUUM RATING	HOSE I.D.		MAX. HOSE O.D.		MAXIMUM WORKING PRESSURE		MINIMUM BEND RADIUS		WEIGHT		CRIMP DIE PART NO.
		INCHES/HG	INCHES	MM	INCHES	MM	PSI	MPA	INCHES	MM	LBS/FT	
540P-4	28	1/4"	6	0.50	13	2750	18.96	1-1/4	32	0.052	0.08	80C-P04
540P-6	28	3/8"	10	0.65	16	2250	15.51	2.0	51	0.086	0.13	80C-P06
540P-8	28	1/2"	13	0.81	21	2000	13.79	3.0	76	0.126	0.19	80C-P08
540P-12	28	3/4"	19	1.06	27	1250	8.62	6.0	152	0.17	0.25	80C-P12

Construction: Polyethylene Core Tube, Fiber Reinforcement, Aqua Perforated Urethane Jacket. Plasticizer free non-leaching core.

Typical applications: Potable water delivery to remote sites. Distilled and de-ionized water. Low moisture permeability.

Temperature range: -10°F to +150°F (-23°C to +66°C)

Fittings: Use 55 series only.

540N

Medium Pressure Hose



HOSE SERIES - DASH SIZE	VACUUM RATING	HOSE I.D.		MAX. HOSE O.D.		MAXIMUM WORKING PRESSURE		MINIMUM BEND RADIUS		WEIGHT		CRIMP DIE PART NO.
		INCHES/HG	INCHES	MM	INCHES	MM	PSI	MPA	INCHES	MM	LBS/FT	
540N-4	28	1/4"	6	0.51	13	2750	18.96	1-1/2	38	0.057	0.09	80C-P04
540N-6	28	3/8"	10	0.65	16	2250	15.51	2.0	51	0.086	0.13	80C-P06
540N-8	28	1/2"	13	0.81	21	2000	13.79	3.0	76	0.126	0.19	80C-P08

Construction: Nylon Core Tube, Fiber Reinforcement, Black Core Hose with Urethane Jacket. Meets or exceeds SAE 100R7 performance.

Typical applications: Hydraulic and pneumatic circuits and systems, agriculture sprayers, urethane foam mixers, robotics, fire resistant fluid and hot water.

Temperature range: -40°F to +212°F (-40°C to +100°C)

Fittings: Use 55 series only.

518C

Non-Conductive Hose



HOSE SERIES - DASH SIZE	VACUUM RATING	HOSE I.D.		MAX. HOSE O.D.		MAXIMUM WORKING PRESSURE		MINIMUM BEND RADIUS		WEIGHT		CRIMP DIE PART NO.
		INCHES/HG	INCHES	MM	INCHES	MM	PSI	MPA	INCHES	MM	LBS/FT	
518C-4	N/A	1/4"	6	0.47	12	2750	18.96	1-1/2	38	0.052	0.08	80C-P04J
518C-6	N/A	3/8"	10	0.63	16	2250	15.51	2.0	51	0.096	0.143	80C-P06
518C-8	N/A	1/2"	13	0.81	21	2250	15.51	3.0	76	0.148	0.221	80C-P08

Construction: Polyester Core Tube, Fiber Reinforcement, Orange Non-perforated Proprietary Jacket. Meets or exceeds SAE 100R7 performance.

Typical applications: Medium pressure hydraulic service where permanent hydraulic circuit exposure and contact with high voltage may be encountered.

Temperature range: -40°F to +212°F (-40°C to +100°C), limited to + 135F (57C) for synthetic hydraulic fluids and water-based fluids.

Fittings: Use 55 series only.

THERMOPLASTIC HOSES

580N

High Pressure Hose



HOSE SERIES - DASH SIZE	TEMPERATURE	HOSE I.D.		MAX. HOSE O.D.		MAXIMUM WORKING PRESSURE		MINIMUM BEND RADIUS		WEIGHT		CRIMP DIE PART NO.
		3/4"	19	1.16	30	2250	15.51	8.0	203	0.21	0.31	
580N-12	-40°F to +212°F	3/4"	19	1.16	30	2250	15.51	8.0	203	0.21	0.31	80C-P12H
580N-16	(-40°C to +100°C)	1"	25	1.48	37.6	2000	13.8	10.0	254	0.376	0.56	80C-P16H





Construction: Polymeric Core, Fiber Reinforcement, Black Perforated Urethane Jacket. Meets or exceeds SAE 100R8 performance.

Typical applications: Hydraulic and pneumatic circuits and systems. Replaces 100R2 rubber hose where greater flexibility, fluid compatibility and cover durability is required. Lighter weight and smaller O.D. than 100R2 rubber hose.

Temperature range: -40°F to +212°F (-40°C to +100°C)

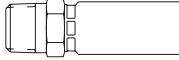
Fittings: Use 58 series only.

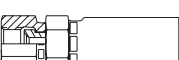
PERMANENT FITTINGS

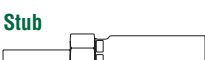
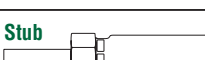
END CONNECTION STYLE	THERMOPLASTIC HOSE 55 SERIES STAINLESS FITTING PART NUMBER	HOSE DASH SIZE
(01) Male Taper Pipe Rigid 	10155-4-4C	-4
	10155-6-6C	-6
	10155-6-6C	-8
	10155-12-12C	-12
(03) Male (JIC) 37° 	10355-4-4C	-4
	10355-6-6C	-6
	10355-8-8C	-8
	10355-12-12C	-10
(06) Female (JIC) 37° Swivel 	10655-4-4C	-4
	10655-6-6C	-6
	10655-8-8C	-8
	10655-12-12C	-12
(AL) A-LOK® Compression 	1AL55-4-4C	-4
	1AL55-6-6C	-6
	1AL55-8-8C	-8
(P6) CPI™ Compression (Nut & Ferrule) 	1P655-4-4C	-4
	1P655-6-6C	-6
	1P655-8-8C	-8
(TU) Tube Stub 	1TU55-4-4C	-4
	1TU55-6-6C	-6
	1TU55-8-8C	-8
	58 Series	
(TU) Tube Stub 	1TU58-12-12	-12
	1TU58-16-16	-16

THERMOPLASTIC ACCESSORIES

HOSE STYLE	(AG) ARMOR GUARDS & (SP) SPRING GUARDS - PART NUMBER PER HOSE DASH SIZE		
520N/540P/549/518C	55AG-4 55SG-4	55AG-6 55SG-6	55AG-8 55SG-8
580N	58AG-12 58SG-12	58AG-16 58SG-16	
	PVC GUARDS - PART NUMBER PER HOSE DASH SIZE		
	-4	-6	-8
520N/540P/549/518C	PV139-1	PV1611-1	PV2014-1
	-12	16	
580N	PV2420-1	PV3224-1	





MINIKRIMP EQUIPMENT

PART NUMBER	DESCRIPTION
94C-080-PFD	Minikrimp Base Unit
94C-001-PFD	Minikrimp w/handpump
94C-002-PFD	Minikrimp w/air/hydraulic
015301	Handpump kit
025411	Air/hydraulic kit
015307	Upright Vice Mount
015306	Upright Bench Mount
015736	Side Vice Mount
94C-MKS	MiniKrimp Stand

MINIKRIMP SPECIFICATION

Approximate Size (with Pump)	7" wide, 5" deep, 15.5" high
Weight (w/o Die Set)	42 lbs. with hand pump
Rating	30 tons force @ 10,000 psi maximum
Capability (steel & brass) 91N series fittings	- 1" SAE 100R1 maximum - 1" SAE 100R2 maximum - 1" SAE 100R16 maximum
Capability (stainless steel) 91N series fittings	- 3/4" SAE 100R1 maximum - 3/4" SAE 100R2 maximum - 3/4" SAE 100R16 maximum
Set Up Time	20 seconds
Full Cycle Time	Approx. 20 seconds to 3 minutes. Note: Cycle times vary depending on hose, fitting, operator, and crimping environment.



MiniKrimp Stand



MiniKrimp with Handpump and Stand



Upright Bench Mount



Upright Vice Mount

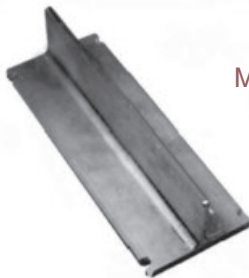

Side Vice Mount



Handpump

DESIGN FEATURES / STANDARDS

Polyethylene Tubing

- FDA, NSF Standard 51 and NSF Standard 61 compliant materials available.
- Meets ASTM D-1693
- Natural “E” Series is made of 100% virgin resin material.
- Available in HD – High Density and FRPE – Flame retardant plenum

Polypropylene

- Polypropylene tubing meets FDA, NSF Standard 51 for all food contact applications
- Polypropylene tubing exhibits excellent chemical resistance to chlorinated water applications
- Polypropylene tubing is commonly used in outdoor applications where UV light stabilization is required

Polyvinyl Chloride (PVC)

- PVC tubing is made from 100% virgin resin material and meets all FDA specifications for materials in contact with food and drugs
- PVC tubing is very flexible (70 Durometer) tubing that is crystal clear and is Ideal for situations where visible fluid flow is necessary (i.e. sight gages for tank identification)

Nylon Tubing

- Flexible Nylon tubing use high grade resins for strength and flexibility for routing in tight spaces
- Semi rigid high strength Nylon use high grade resins without the addition of plasticizers for higher pressure tubing applications
- Pure Air Tubing (PAT) is the tubing choice for pure air systems (Semiconductor) due to its cleanliness in addition to excellent chemical and UV light resistance

Polyurethane

- Polyurethane tubing is a flexible, kink resistant and abrasion resistant material commonly used in pneumatic applications
- Polyurethane is available in multiple transparent and opaque colors for system color coding
- Polyurethane is available in the following durometers (measurement of material hardness):
- Low Durometer (85-most flexible, very soft)
- Medium Durometer (90-less flexible)
- High Durometer (>95-least flexible, highest pressures)

THERMOPLASTIC TUBING SELECTION GUIDE

TEMPERATURE RATING	MATERIAL	PRODUCT FAMILY	SUGGESTED MARKETS AND APPLICATIONS
-80°F to 150°F [-62°C to 66°C]	Polyethylene	E	Potable water, chemical transfer, and low cost, low pressure pneumatics, NSF-51 & 61
		FRPE (Flame Resistant)	Pneumatic controls in HVAC/plenum space (UL 1820), DUBL-Barb fitting from Parker Brass
-40°F to 150°F [-18°C to 65°C]	Clear Vinyl	PV	Low pressure chemical requiring high clarity and flexibility FDA 21CFR compliant.
-80°F to 175°F [-62°C to 79°C]	Polyethylene	PE	Economical, low pressure pneumatics, NSF-51
		HDPE (High Density)	Chemical transfer and low cost pneumatics
-40°F to 180°F [-40°C to 82°C]	Urethane	U	Pneumatic controls requiring high flexibility, kink resistance and movement
		HU	High pressure pneumatics requiring flexibility and kink resistance, Robotics
		LU	Low pressure pneumatics requiring extreme flexibility and kink resistance, pneumatic logic boards
-65°F to 200°F [-54°C to 93°C] -40°F to 200°F [-40°C to 93°C] -60°F to 200°F [-51°C to 93°C]	Nylon	N	Pneumatic and petroleum-based chemical transfer
		PAT	Pure air and gas distribution systems, Semiconductor
		NR	High pressure pneumatic, lubrication, and Marine control systems
0°F to 200°F [-18°C to 93°C]	Polypropylene	PP	Food contact and chemical transfer applications, chlorinated water, NSF-51

PLASTIC TUBING

MATERIAL	PRODUCT FAMILY	O.D. INCHES	I.D. INCHES	WALL INCHES	NET WEIGHT PER 100FT (IBS)	WORKING PRESSURE @ 73°F (PSI)	BOX LENGTH	PART NUMBER (ALL P/N'S REF. BLACK TUBING)*
Polyethylene	E	1/4"	0.170	0.040	1.10	120	500'	EB-43-0500
		3/8"	0.251	0.062	2.50	125	500'	EB-64-0500
		1/2"	0.375	0.062	3.60	90	500'	EB-86-0500
	PE	1/4"	0.170	0.040	1.10	100	1000'	PE-4-040-BK-1000
		3/8"	0.251	0.062	2.50	87	500'	PE-6-062-BK-0500
		1/2"	0.375	0.062	3.40	62	250'	PE-8-062-BK-0250
	FRPE	1/4"	0.170	0.040	1.17	160	250'	1FRPE4-0250
		3/8"	0.251	0.062	2.71	195	250'	1FRPE6-0250
		1/2"	0.375	0.062	3.80	135	250'	1FRPE8-0250
High Density Polyethylene	HDPE	1/4"	0.170	0.040	1.10	300	250'	HDPE-43-0250
		3/8"	0.251	0.062	2.50	300	250'	HDPE-64-0250
Nylon	N	1/4"	0.180	0.035	1.10	250	250'	NB-4-035
		3/8"	0.275	0.050	2.34	250	250'	NB-6-050
		1/2"	0.375	0.062	3.94	250	250'	NB-8-062
	PAT	1/4"	0.170	0.040	1.24	300	250'	PAT4-BLK-250
		3/8"	0.251	0.062	2.82	350	250'	PAT6-BLK-250
		1/2"	0.375	0.062	3.95	235	500'	PAT8-BLK-500
	NR	1/4"	0.18	0.035	1.1	425	250'	NBR-4-035
		3/8"	0.279	0.048	2.2	425	250'	NBR-6-048
		1/2"	0.375	0.062	3.8	375	250'	NBR-8-062
Polypropylene	PP	1/4"	0.17	0.040	1.01	300	500'	PP-43-0500
		3/8"	0.25	0.062	2.35	300	500'	PP-64-0500
		1/2"	0.375	0.062	3.28	225	250'	PP-86-0250
Urethane	U	1/4"	0.2	0.062	1.8	125	250'	U-42-BLK-0250
		3/8"	0.25	0.062	3	125	250'	U-64-BLK-0250
		1/2"	0.375	0.062	4.2	85	250'	U-86-BLK-0250
	HU	1/4"	0.16	0.045	1.55	180	500'	HU-4-BLK-0500
		3/8"	0.25	0.062	3.27	180	500'	HU-6-BLK-0500
		1/2"	0.32	0.09	6.18	180	250'	HU-8-BLK-0250
	LU	1/8"	0.062	0.031	0.44	145	100'	LU-2-BLK-0100
		1/4"	0.125	0.062	1.78	145	100'	LU-4-BLK-0100
		5/16"	0.187	0.062	2.38	100	100'	LU-5-BLK-0100

PLASTIC TUBING

MATERIAL	PRODUCT FAMILY	O.D. INCHES	I.D. INCHES	WALL INCHES	NET WEIGHT PER 100FT (IBS)	WORKING PRESSURE @ 73°F (PSI)	BOX LENGTH	PART NUMBER CLEAR VINYL
Clear Vinyl	PV	1/8"	0.062	0.031	0.48	35	100'	PV21-1
		1/6"	0.125	0.025	0.58	35	100'	PV32-1
		1/4"	0.125	0.062	2.52	65	100'	PV42-1
		3/8"	0.25	0.062	3.15	55	100'	PV64-1
		1/2"	0.375	0.062	4.41	45	100'	PV86-1
		5/8"	0.5	0.062	5.66	30	100'	PV108-1
		11/16"	0.5	0.094	8.94	40	100'	PV118-1
		3/4"	0.5	0.125	12.59	45	100'	PV128-1
		1"	0.75	0.125	17.62	35	100'	PV1612-1
		1-1/4"	0.75	0.25	40.28	55	50'	PV2012-1
2-1/2"	2"	0.25	90.63	35	50'	PV4032-1		

THERMOPLASTIC FITTINGS

TRUESEAL™ THERMOPLASTIC PUSH-IN FITTINGS

The patented* TrueSeal™ push-to-connect thermoplastic fittings are lightweight, field attachable, and connect to plastic tubing without the use of tools.

Features

- All components in TrueSeal™ fittings are manufactured from FDA compliant materials and are NSF-51 listed for contact with food.
- Gray acetal TrueSeal™ fittings meet NSF-61 requirements for drinking water (potable water) system components.
- All-plastic body designs offer reduced weight, eliminate rust, corrosion, and system contamination in applications where metal components cannot be tolerated.
- Collets are offered in either a patented all-plastic design for use with flexible tubing or with a metal grip edge made from 300 series stainless steel for use on all tubing including copper.
- Extra deep tube seat in fitting body provides support to reduce side-load leakage.
- Elastomer o-ring seal provides positive compression on tubing O.D. in vacuum or pressure applications.
- Removable collet design permits o-ring replacement in the field. Collets are available in colors for easy color-coding of systems.
- Tube stem adapters provide a wide range of tube-to-port jump size potential and allow elbows and tees to swivel for positive tube routing alignment. Connections made with metal gripper collets may require tube stems to be replaced upon reconnection.

Working Pressure

TrueSeal™ fittings are rated for the pressures listed below or at 1/4 (one-fourth) of the rated burst pressure of the tubing

FITTING SIZE	ACETAL (PSI)	POLYPROPYLENE (PSI)	KYNAR® (PSI)
1/4"	300	150	300
5/16"	300		
3/8"	300	150	300
1/2"	250	150	
Temperature Range	-20°F (-29°C) to +180°F (85°C)	0°F (-18°C) to +225°F (110°C)	0°F (-18°C) to +275°F (135°C)

These pressure ratings are based on tests conducted with Series NR tubing at 73°F.

- Actual-working pressures will be lower at elevated temperatures. Consult division.
- Meets pressure integrity tests of NSF-53 and NSF-58

Assembly Instructions

Tube Sizes O.D. Tolerance Insertion Depth

TUBE SIZE O.D.	O.D. TOLERANCE	INSERTION DEPTH
5/32"	+/- .005	9/16"
1/4"	+/- .005	11/16"
5/16"	+/- .005	13/16"
3/8"	+/- .005	3/4"
1/2"	+/- .005	7/8"





1. Cut tubing square and clean. (Use a Parker plastic tube cutter, Part No. PTC.)
2. Mark from end of tube the length of insertion (see table above).
3. Push tube into the fitting until it bottoms out.
4. To remove, depress collet and pull tubing out.
5. Use Parker TrueSealant™ (Part No. PTS) on threads.







These products are available from Brass Products Division



TRUESEAL™ FITTINGS

TRUESEAL™ FITTINGS	GRAY ACETAL (EPDM SEAL)	WHITE POLYPROPYLENE (EPDM SEAL)	NATURAL KYNAR VITON SEAL	NOMINAL TUBE O.D. (INCHES)	NPTF THREAD SIZE (INCHES)
(MC) Male Connector 	A4MC2-MG	PP4MC2	F4MC2	1/4"	1/8"
	A4MC4-MG	PP4MC4	F4MC4	1/4"	1/4"
	A4MC6-MG	PP4MC6	F4MC6	1/4"	3/8"
	A6MC4-MG	PP6MC4	F6MC4	3/8"	1/4"
	A6MC6-MG	PP6MC6	F6MC6	3/8"	3/8"
	A8MC8-MG	PP8MC8	N/A	1/2"	1/2"
(EU) Elbow Union 	A4EU4-MG	PP4EU4	F4EU4	1/4"	N/A
	A6EU4-MG	PP6EU4	F6EU4	3/8"	N/A
	A6EU6-MG	PP6EU6	F6EU6	3/8"	N/A
	A8EU8-MG	PP8EU8	N/A	1/2"	N/A
(MES) Male Elbow Swivel 	A4MES2-MG	PP4MES2	F4MES2	1/4"	1/8"
	A4MES4-MG	PP4MES4	F4MES4	1/4"	1/4"
	A4MES6-MG	PP4MES6	M4MES6	1/4"	3/8"
	A6MES4-MG	PP6MES4	F6MES4	3/8"	1/4"
	A6MES6-MG	PP6MES6	F6MES6	3/8"	3/8"
	A8MES6-MG	PP8MES6	N/A	1/2"	3/8"
	A8MES8-MG	PP8MES8	N/A	1/2"	1/2"
	(UC) Union Connector 	A4UC4-MG	PP4UC4	F4UC4	1/4"
A6UC4-MG		PP6UC4	F6UC4	3/8"-1/4"	N/A
A6UC6-MG		PP6UC6	F6UC6	3/8"	N/A
A8UC6-MG		PP8UC6	N/A	1/2"-3/8"	N/A
A8UC8-MG		PP8UC8	N/A	1/2"	N/A

TRUESEAL™ FITTINGS	GRAY ACETAL (EPDM SEAL)	WHITE POLYPROPYLENE (EPDM SEAL)	NATURAL KYNAR VITON SEAL	NOMINAL TUBE O.D. (INCHES)	NPTF THREAD SIZE (INCHES)
(TMC) Tube Stem Adapter Tube Stem to Pipe 	A4TMC2-MG	PP4TMC2	F4TMC2	1/4"	1/8"
	A4TMC4-MG	PP4TMC4	F4TMC4	1/4"	1/4"
	A6TMC4-MG	PP6TMC4	F6TMC4	3/8"	1/4"
	A6TMC6-MG	PP6TMC6	F6TMC6	3/8"	3/8"
	A8TMC6-MG	PP8TMC6	N/A	1/2"	3/8"
	A8TMC8-MG	PP8TMC8	N/A	1/2"	1/2"
(BU) Bulkhead Union Tube-to-Tube 	A4BU4-MG	PP4BU4	F4BU4	1/4"	N/A
	A6BU4-MG	PP6BU4	N/A	3/8"-1/4"	N/A
	A6BU6-MG	PP6BU6	F6BU6	3/8"	N/A
	A8BU8-MG	N/A	N/A	1/2"	N/A
(TEU) Tube Elbow Union Tube to Tube Stem 	A4TEU4-MG	PP4TEU4	F4TEU4	TUBE O.D. 1/4"-1/4"	STEM O.D. N/A
	A6TEU6-MG	PP6TEU6	F6TEU6	3/8"-3/8"	N/A
	A8TEU8-MG	PP8TEU8	N/A	1/2"-1/2"	N/A
(ME) Male Elbow (Tube-to-Pipe) 	A4ME2-MG	PP4ME2	F4ME2	1/4"	1/8"
	A4ME4-MG	PP4ME4	F4ME4	1/4"	1/4"
	A4ME6-MG	PP4ME6	F4ME6	1/4"	3/8"
	A6ME4-MG	PP6ME4	F6ME4	3/8"	1/4"
	A6ME6-MG	PP6ME6	F6ME6	3/8"	3/8"
(TPL) Plug 	A4TPL	PP4TPL	F4TPL	FITTING SIZE 1/4"	
	A6TPL	PP6TPL	F6TPL	3/8"	
	A8TPL	PP8TPL	N/A	1/2"	

These products are available from Brass Products Division

THERMOPLASTIC FITTINGS

FAST & TITE® THERMOPLASTIC FITTINGS

Fast & Tite® fittings are the most complete line of plastic fittings for thermoplastic tubing in the industry.

Fast & Tite® thermoplastic tube fittings from Parker will prove to be the answer to your tubing connector needs. Patented Fast & Tite® fittings install in seconds without tools and provide a tight, sure, leak proof seal without clamps or adjustments. A unique 302 stainless steel grab ring for tube retention, coupled with a Nitrile O-Ring for positive seal, assures good tube connection with only hand tight assembly. A plastic grab ring is also available upon special request. Vibration or tube movement will not break the seal and cause leakage.

Preassembled in either highly inert polypropylene, or strong, durable nylon, Fast & Tite® fittings are the answer to full flow thermoplastic tubing system requirements.

When necessary, Fast & Tite® fittings can be disassembled by hand for fast system drainage. Fittings are completely Field Attachable. Parts are easily replaced. O-Rings are standard size and universally available. (For applications requiring other than Nitrile O-Rings, consult your Fast & Tite® distributor.)

Use Fast & Tite® fittings with Parker Parflex tubing or other plastic, glass or metal tubing for low pressure or vacuum lines up to the pressure limits shown below. When using clear vinyl tubing or urethane tubing, it is necessary to use a TS tube support. A tube support can be used with any tubing for maximum holding power where tensiling, vibration or pressure spikes may occur.

Fast & Tite® fittings meet FDA and NSF-51 requirements for food contact.

Working Pressures

Air-Oil-Water Pressure in PSI

TUBE O.D.	UP TO 75°F	76°F TO 125°F	126°F TO 175°F
1/4"	300	300	300
5/16"	300	300	300
3/8"	250	250	150
1/2"	200	200	150
5/8"	150	100	50

Ratings are based on use with copper tubing, and in all cases represent the maximum recommended working pressure of the fitting only. Working pressures (vs. temperatures) of other types of tubing may limit the tube and fitting assembly to pressures lower than shown above. Consult factory for recommendations on applications other than shown above.

Temperature Range:

Black/White Polypropylene:

0°F (-18°C) to +212°F (+100°C)

White Nylon: -40°F (-40°C) to +200°F (+93°C)

Fast Assembly

Step 1. Cut the tube squarely and remove any burrs.

Step 2. Mark from end of tube the length of insertion. If using a tube support, insert fully into tube and then mark from end of tube support length of insertion. (See table below)

TUBE O.D.	INSERT LENGTH WITH TUBE SUPPORT	INSERT LENGTH WITHOUT TUBE SUPPORT
1/4"	5/8"	9/16"
5/16"	5/8"	9/16"
3/8"	13/16"	3/4"
1/2"	7/8"	13/16"
5/8"	1"	15/16"

Step 3.

Loosen nut on fitting until three threads are visible.

Fittings for glass tubes must be disassembled and the grab ring removed. If the fitting has been disassembled the components are to be placed in the following order: Fitting body, o-ring, spacer, grab ring and nut. Assemble the nut until three threads are showing on the body before inserting tube.





Step 4.



Moisten end of the tube with water. Push the tube **Straight** into fitting until it bottoms on the fitting's shoulder. Tighten nut by hand. Additional tightening should not be necessary, but 1/4 additional turn may be added if desired. **Do not over tighten** nut as the threads will strip and the fitting will not function properly. A proper assembly will **not** show the insertion mark extending beyond the nut. If the insertion mark is visible, then steps 1 thru 4 must be repeated.

These products are available from Brass Products Division



FAST AND TITE FITTINGS

FAST AND TITE FITTINGS	WHITE POLYPROPYLENE	BLACK POLYPROPYLENE	WHITE NYLON	NOMINAL TUBE O.D. (INCHES)	NPTF THREAD SIZE (INCHES)
(MC) Male Connector Tube to Male Pipe 	W4MC2	P4MC2	N4MC2	1/4"	1/8"
	W4MC4	P4MC4	N4MC4	1/4"	1/4"
	W6MC4	P6MC4	N6MC4	3/8"	1/4"
	W6MC6	P6MC6	N6MC6	3/8"	3/8"
	W8MC6	P8MC6	N8MC6	1/2"	3/8"
	W8MC8	P8MC8	N8MC8	1/2"	1/2"
(EU) Elbow Union Tube to Tube 	W4EU4	P4EU4	N4EU4	1/4"	N/A
	W6EU4	P6EU4	N6EU4	3/8"-1/4"	N/A
	W6EU6	P6EU6	N6EU6	3/8"	N/A
	W8EU6	P8EU6	N8EU6	1/2"-3/8"	N/A
(ME) Male Elbow Tube to Male Pipe 	W4ME2	P4ME2	N4ME2	1/4"	1/8"
	W4ME4	P4ME4	N4ME4	1/4"	1/4"
	W4ME6	P4ME6	N4ME6	1/4"	3/8"
	W6ME4	P6ME4	N6ME4	3/8"	1/4"
	W6ME6	P6ME6	N6ME6	3/8"	3/8"
	W6ME8	P6ME8	N6ME8	3/8"	1/2"
	W8ME6	P8ME6	N8ME6	1/2"	3/8"
	W8ME8	P8ME8	N8ME8	1/2"	1/2"
(BU) Bulkhead Union Tube-to-Tube 	W4BU4	P4BU4	N4BU4	1/4"	N/A
	W6BU6	P6BU6	N6BU6	3/8"	N/A
	W8BU8	P8BU8	N8BU8	1/2"	N/A
(UC) Union Connector Tube to Tube 	W4UC4	P4UC4	N4UC4	1/4"	N/A
	W6UC4	P6UC4	N6UC4	3/8"-1/4"	N/A
	W6UC6	P6UC6	N6UC6	3/8"	N/A
	W8UC6	P8UC6	N8UC6	1/2"-3/8"	N/A
	W8UC8	P8UC8	N8UC8	1/2"	N/A

FAST AND TITE FITTINGS	WHITE POLYPROPYLENE	BLACK POLYPROPYLENE	WHITE NYLON	NOMINAL TUBE O.D. (INCHES)	NPTF THREAD SIZE (INCHES)
(FE) Female Elbow Tube to Female Pipe 	W4FE2	P4FE2	N4FE2	1/4"	1/8"
	W4FE4	P4FE4	N4FE4	1/4"	1/4"
	W6FE4	P6FE4	N6FE4	3/8"	1/4"
	W6FE6	P6FE6	N6FE6	3/8"	3/8"
	W8FE8	P8FE8	N8FE8	1/2"	1/2"
(FC) Female Connector Tube to Female Pipe 	W4FC2	P4FC2	N4FC2	1/4"	1/8"
	W4FC4	P4FC4	N4FC4	1/4"	1/4"
	W6FC4	P6FC4	N6FC4	3/8"	1/4"
	W6FC6	P6FC6	N6FC6	3/8"	3/8"
	W8FC6	P8FC6	N8FC6	1/2"	3/8"
	W8FC8	P8FC8	N8FC8	1/2"	1/2"
(TU) Tee Union Tube to Tube 	W4TU4	P4TU4	N4TU4	1/4"	N/A
	W6TU6	P6TU6	N6TU6	3/8"	N/A
	W8TU8	P8TU8	N8TU8	1/2"	N/A

These products are available from Brass Products Division

THERMOPLASTIC FITTINGS

Par-Barb Thermoplastic Fittings

Par-Barb fittings are precision injection molded from high strength, chemically inert, thermoplastic materials.

The specially engineered four-barb design generates the maximum gripping and sealing power when combined with a hose clamp. The unique barb design requires the tube or hose to expand slightly to accept the fitting, providing a positive seal on the barbs.

Par-Barb fittings are widely used with Parflex clear vinyl tubing, urethane tubing and a variety of rubber tubing and hose.

Par-Barb fittings meet FDA and NSF-51 specifications for food contact.

Par-Barb is recommended in medical, pollution control, food and beverage applications. Other uses include irrigation, instrumentation, reverse osmosis and deionized water systems.

Temperature range:

Black Polyethylene: -65°F (-54°C) to +190°F (+88°C.)

White Nylon: -40°F (-40°C) to +200°F (+93°C.)

Working Pressures:









Par-Barb fittings are generally used in systems where pressures do not exceed 125 PSI. When used in excess of 125 PSI, the customer in his particular application should test Par-Barb fittings, in all sizes.

Ambient and fluid temperatures, type of fluid conveyed, hose or tubing used, clamping mechanism employed and conditions of mechanical abuse, govern operating pressures of Par-Barb fittings.



These products are available from Brass Products Division

PAR-BARB FITTINGS

PAR-BARB FITTINGS	BLACK HIGH DENSITY LINEAR POLETHYLENE	WHITE NYLON	TUBE OR HOSE I.D.	NPTF THREAD SIZE (INCHES)
(EUB) Elbow Union 	P4EUB4	N4EUB4	1/4"	N/A
	P6EUB6	N6EUB6	1/4"	N/A
	P8EUB6	N8EUB6	1/2"-3/8"	N/A
	P8EUB8	N8EUB8	1/2"	N/A
(MTB) Tee Male Branch 	P4MTB2	N4MTB2	1/4"	1/8"
	P4MTB4	N4MTB4	1/4"	1/4"
	P4MTB6	N4MTB6	1/4"	3/8"
	P6MTB4	N6MTB4	3/8"	1/4"
	P6MTB6	N6MTB6	3/8"	3/8"
	P6MTB8	N6MTB8	3/8"	1/2"
	P8MTB6	N8MTB6	1/2"	3/8"
	P8MTB8	N8MTB8	1/2"	1/2"
(HPL) Hex Head Pipe Plug 	P2HPL	N2HNL	N/A	1/8"
	P4HPL	N4HNL	N/A	1/4"
	P6HPL	N6HNL	N/A	3/8"
	P8HPL	N8HNL	N/A	1/2"
(TUB) Tee Union 	P2TUB2	N2TUB2	TEE I.D. 1/8"	STEM I.D. 1/8"
	P4TUB4	N4TUB4	1/4"	1/4"
	P6TUB4	N6TUB4	3/8"	1/4"
	P6TUB6	N6TUB6	3/8"	3/8"
	P6TUB8	N6TUB8	3/8"	1/2"
	P8TUB6	N8TUB6	1/2"	3/8"
	P8TUB8	N8TUB8	1/2"	1/2"
	(MEB) Male Elbow Connector 	P4MEB2	N4MEB2	1/4"
P4MEB4		N4MEB4	1/4"	1/4"
P4MEB6		N4MEB6	1/4"	3/8"
P6MEB4		N6MEB4	3/8"	1/4"
P6MEB8		N6MEB8	3/8"	1/2"
P8MEB4		N8MEB4	1/2"	1/4"
P8MEB6		N8MEB6	1/2"	3/8"
P8MEB8		N8MEB8	1/2"	1/2"
(UCB) Union Connector 	P2UCB2	N2UCB2	1/8"	1/8"
	P4UCB4	N4UCB4	1/4"	1/4"
	P6UCB6	N6UCB6	3/8"	3/8"
	P8UCB6	N8UCB6	1/2"	3/8"
	P8UCB8	N8UCB8	1/2"	1/2"
(HPN) Hex Pipe Nipple 	P2HPN2	N2HNN2	1/8"	1/8"
	P4HPN4	N4HNN4	1/4"	1/4"
	P6HPN6	N6HNN6	3/8"	3/8"
	P8HPN8	N8HNN8	1/2"	1/2"
(MCB) Male Connector 	P4MCB2	N4MCB2	1/4"	1/8"
	P4MCB4	N4MCB4	1/4"	1/4"
	P6MCB4	N6MCB4	3/8"	1/4"
	P6MCB6	N6MCB6	3/8"	3/8"
	P8MCB6	N8MCB6	1/2"	3/8"
	P8MCB8	N8MCB8	1/2"	1/2"

These products are available from Brass Products Division

Introduction

polyflex® reinforced polymer hose is available in a wide variety of constructions, styles, and lengths to meet a vast number of industrial and offshore applications. Styles shown on these pages are compatible with Parker MPI™ Fittings and offer these benefits:

- Flexible with small outside diameter for tight routing
- Abrasion resistant polymer cover for longer life
- Chemical-resistant tube and cover
- Steel-reinforced styles resist kinks

TYPICAL APPLICATIONS:

- Offshore oil and gas platforms and satellites
- Chemical injection lines
- Hydraulic controls
- Replacement of hard tube lines
- Pressure testing
- Tank and process vessel cleaning

polyflex® Hose



PARKER PART NO.	MIN. I.D.	MAX. O.D.	MAX. WORKING PRESSURE	MIN. BURST PRESSURE	MIN. BEND RADIUS	WEIGHT
	INCH	INCH	PSI	PSI	INCH	LBS/FT
2020N-02V30	0.12	0.24	9,280	23,200	1.18	0.05
2240D-025V34	0.17	0.30	17,400	43,500	2.95	0.067
2245N-04V00	0.25	0.50	10,440	26,100	2.76	0.17
2245N-04V02	0.25	0.50	10,440	26,100	2.76	0.17
2245N-04V04	0.25	0.50	10,440	26,100	2.76	0.17
2380N-04V00	0.25	0.53	16,240	40,600	2.76	0.22
2380N-04V02	0.25	0.53	16,240	40,600	2.76	0.22
2380N-04V04	0.25	0.53	16,240	40,600	2.76	0.22
2380N-04V01	0.25	0.53	16,240	40,600	2.76	0.22
2380N-04V33	0.25	0.50	13,200	33,000	3.50	0.17
2390N-06V13	0.4	0.70	10,300	25,810	3.00	0.28
2440N-08V37	0.5	0.88	20,400	51,000	7.87	0.63
2440N-08V71	0.5	0.88	20,400	51,000	7.87	0.63
2440N-12V37	0.81	1.19	14,500	37,500	10.00	0.93
2440N-12V71	0.81	1.19	14,500	37,500	10.00	0.93

Temperature range: -40° to +140°F (-40° to +60°C). Contact the factory for temperatures outside this range.

For additional information about polyflex® hose, including information about construction, typical applications, working pressure and installation, contact your authorized Parker Instrumentation Distributor or polyflex® at (281) 530-5300.

How to Order Polyflex® Hose Assemblies

Example Hose Assembly Number: **2244NAYAY111108C10-600**

2244N	AY	AY	11	11	08	C	10	-	XXX
(A)	(B)		(C)		(D)	(E)	(F)		Indicate Length in Inches

<p>A</p> <p>This series of numbers will indicate the hose base number.</p> <p>Examples:</p> <p>2040N - 02 2040N - 04</p> <p>2240D - 025 2245D - 03 2243D - 03</p> <p>2390N - 04 2390N - 06 2390N - 08 2390N - 12</p> <p>2440D - 025 2440D - 05 2440N - 08 2440N - 12</p> <p>2640N - 08 2640N - 12</p> <p>2740D - 03 2740D - 05</p> <p>2840D - 03</p>	<p>B</p> <p>These two letters will indicate the STYLE of connection. End 1 & End 2</p> <p>01 = NPT Pipe, Male, Rigid 02 = NPT Pipe; Female Rigid 06 = JIC 37 degree.; Female Swivel 07 = NPSM Pipe; Female Swivel 60° 92 = BSP Pipe; Female Swivel AY = Type M; Female Swivel 58° YA = Type M; Male (adaptor ends) C9 = Metric; Female, Swivel 24/O-Ring D9 = BSP; Male, Rigid Y1 = MP Nipple; Male, w/ GNut & Collar Y2 = MP Nipple; Male, wo/ GNut & Collar Y3 = HP Nipple; Male, w/ GNut & Collar Y4 = HP Nipple; Male, wo/ GNut & Collar Y5 = MP Flare; Male, Rigid Y6 = HP Flare; Male, Rigid 5Y = MP Flare; Female 6Y = HP Flare; Female</p>	<p>C</p> <p>This part will contain a dash followed by a one or two digit number indicating the end connection size. End 1 & End 2</p> <p>UNF</p> <p>1 = 1/4" - 28 UNF 2 = 5/16" - 24 UNF 3 = 3/8" - 24 UNF 4 = 7/16" - 20 UNF 5 = 1/2" - 20 UNF 6 = 9/16" - 18 UNF 7 = 5/8" - 18 UNF 8 = 3/4" - UNF 9 = 10 = 7/8" - 14 UNF 11 = 1" - 12 UNF 12 = 1 1/16" - 12 UNF 13 = 1 1/8" - 12 UNF 14 = 15 = 1 1/4" - 12 UNF 16 = 1 5/16" - 12 UNF 17 = 1 3/8" - 12 UNF 18 = 19 = 1 1/2" - 12 UNF 20 = 1 5/8" - 12 UNF</p> <p>NPT</p> <p>1 = 1/16-27 2 = 1/8-27 4 = 1/4-18 6 = 3/8-18 8 = 1/2-14 12 = 3/4-14 16 = 1-11 1/2 20 = 1 1/4-11 1/2 24 = 1 1/2-11 1/2 32 = 2-11 1/2</p> <p>Medium and High Pressure Tube Male or female, sized by nominal tube O.D.</p> <p>04 = 1/4" tube 06 = 3/8" tube 09 = 9/16" tube 12 = 3/4" tube 16 = 1" tube</p>	<p>D</p> <p>When specifying hose size, indicate the two digit code.</p> <table border="1"> <thead> <tr> <th>Hose Dash Size</th> <th>Code</th> </tr> </thead> <tbody> <tr><td>01</td><td>01</td></tr> <tr><td>015</td><td>1A</td></tr> <tr><td>02</td><td>02</td></tr> <tr><td>025</td><td>2B</td></tr> <tr><td>03</td><td>03</td></tr> <tr><td>04</td><td>04</td></tr> <tr><td>05</td><td>05</td></tr> <tr><td>06</td><td>06</td></tr> <tr><td>08</td><td>08</td></tr> <tr><td>10</td><td>10</td></tr> <tr><td>12</td><td>12</td></tr> <tr><td>16</td><td>16</td></tr> <tr><td>20</td><td>20</td></tr> <tr><td>24</td><td>24</td></tr> <tr><td>32</td><td>32</td></tr> </tbody> </table>	Hose Dash Size	Code	01	01	015	1A	02	02	025	2B	03	03	04	04	05	05	06	06	08	08	10	10	12	12	16	16	20	20	24	24	32	32	<p>E</p> <p>Indicate the fitting material.</p> <p>S = Steel B = Brass C = Stainless Steel</p>	<p>F</p> <p>This series of numbers will indicate the hose Variation Number.</p> <p>Examples:</p> <p>2040N - 02 V00 2020N - 02 V30</p> <p>2240D - 025 V34 2245N - 16 V30 2245N - 20 V30 2244N - 025 V00 2244N - 08 V10</p> <p>2380N - 04 V33 2380N - 04 V00 2380N - 05 V00</p> <p>2440N - 08 V37 2440N - 12 V37 2440N - 16 V37</p> <p>2640D - 025 V32 2640N - 12 V32</p> <p>2740D - 03 V30 2740D - 05 V32</p> <p>2840D - 03 V34</p>
Hose Dash Size	Code																																				
01	01																																				
015	1A																																				
02	02																																				
025	2B																																				
03	03																																				
04	04																																				
05	05																																				
06	06																																				
08	08																																				
10	10																																				
12	12																																				
16	16																																				
20	20																																				
24	24																																				
32	32																																				

OFFER OF SALE

The items described in this document and other documents or descriptions provided by Parker Hannifin Corporation, its subsidiaries and its authorized distributors are hereby offered for sale at prices to be established by Parker Hannifin Corporation, its subsidiaries and its authorized distributors. This offer and its acceptance by any customer ("Buyer") shall be governed by all of the following Terms and Conditions. Buyer's order for any such items, when communicated to Parker Hannifin Corporation, its subsidiary or an authorized distributor ("Seller") verbally or in writing, shall constitute acceptance of this offer.

1. Terms and Conditions of Sale: All descriptions, quotations, proposals, offers, acknowledgments, acceptances and sales of Seller's products are subject to and shall be governed exclusively by the terms and conditions stated herein. Buyer's acceptance of any offer to sell is limited to these terms and conditions. Any terms or conditions in addition to, or inconsistent with those stated herein, proposed by Buyer in any acceptance of an offer by Seller, are hereby objected to. No such additional, different or inconsistent terms and conditions shall become part of the contract between Buyer and Seller unless expressly accepted in writing by Seller. Seller's acceptance of any offer to purchase by Buyer is expressly conditional upon Buyer's assent to all the terms and conditions stated herein, including any terms in addition to, or inconsistent with those contained in Buyer's offer. Acceptance of Seller's products shall in all events constitute such assent.

2. Payment: Payment shall be made by Buyer net 30 days from the date of delivery of the items purchased hereunder. Amounts not timely paid shall bear interest at the maximum rate permitted by law for each month or portion thereof that the Buyer is late in making payment. Any claims by Buyer for omissions or shortages in a shipment shall be waived unless Seller receives notice thereof within 30 days after Buyer's receipt of the shipment.

3. Delivery: Unless otherwise provided on the face hereof, delivery shall be made F.O.B. Seller's plant. Regardless of the method of delivery, however, risk of loss shall pass to Buyer upon Seller's delivery to a carrier. Any delivery dates shown are approximate only and Seller shall have no liability for any delays in delivery.

4. Warranty: Seller warrants that items sold hereunder shall be free from defects in material or workmanship. **THIS WARRANTY COMPRISES THE SOLE AND ENTIRE WARRANTY PERTAINING TO ITEMS PROVIDED HEREUNDER. SELLER MAKES NO OTHER WARRANTY, GUARANTEE, OR REPRESENTATION OF ANY KIND WHATSOEVER. ALL OTHER WARRANTIES, INCLUDING BUT NOT LIMITED TO, MERCHANTABILITY AND FITNESS FOR PURPOSE, WHETHER EXPRESS, IMPLIED, OR ARISING BY OPERATION OF LAW, TRADE USAGE, OR COURSE OF DEALING ARE HEREBY DISCLAIMED.**

NOTWITHSTANDING THE FOREGOING, THERE ARE NO WARRANTIES WHATSOEVER ON ITEMS BUILT OR ACQUIRED WHOLLY OR PARTIALLY, TO BUYER'S DESIGNS OR SPECIFICATIONS.

5. Limitation Of Remedy: SELLER'S LIABILITY ARISING FROM OR IN ANY WAY CONNECTED WITH THE ITEMS SOLD OR THIS CONTRACT SHALL BE LIMITED EXCLUSIVELY TO REPAIR OR REPLACEMENT OF THE ITEMS SOLD, AT SELLER'S SOLE OPTION. IN NO EVENT SHALL SELLER BE LIABLE FOR ANY INCIDENTAL, CONSEQUENTIAL OR SPECIAL DAMAGES OF ANY KIND OR NATURE WHATSOEVER, INCLUDING BUT NOT LIMITED TO LOST PROFITS ARISING FROM OR IN ANY WAY CONNECTED WITH THIS AGREEMENT OR ITEMS SOLD HEREUNDER, WHETHER ALLEGED TO ARISE FROM BREACH OF CONTRACT, EXPRESS OR IMPLIED WARRANTY, OR IN TORT, INCLUDING WITHOUT LIMITATION, NEGLIGENCE, FAILURE TO WARN OR STRICT LIABILITY.

6. Changes, Reschedules and Cancellations: Buyer may request to modify the designs or specifications for the items sold hereunder as well as the quantities and delivery dates thereof, or may request to cancel all or part of this order, however, no such requested modification or cancellation shall become part of the contract between Buyer and Seller unless accepted by Seller in a written amendment to this Agreement. Acceptance of any such requested modification or cancellation shall be at Seller's discretion, and shall be upon such terms and conditions as Seller may require.

7. Special Tooling: A tooling charge may be imposed for any special tooling, including without limitation, dies, fixtures, molds and patterns, acquired to manufacture items sold pursuant to this contract. Such special tooling shall be and remain Seller's property notwithstanding payment of any charges by Buyer. In no event will Buyer acquire any interest in apparatus belonging to Seller which is utilized in the manufacture of the items sold hereunder, even if such apparatus has been specially converted or adapted for such manufacture and not withstanding any charges paid by Buyer. Unless otherwise agreed, Seller shall have the right to alter, discard or otherwise dispose of any special tooling or other property in its sole discretion at any time.

8. Buyer's Property: Any designs, tools, patterns, materials, drawings, confidential information or equipment furnished by Buyer or any other items which become Buyer's property, may be considered obsolete and may be destroyed by Seller after two (2) consecutive years have elapsed without Buyer placing an order for the items which are manufactured using such property, Seller shall not be responsible for any loss or damage to such property while it is in Seller's possession or control.

9. Taxes: Unless otherwise indicated on the face hereof, all prices and charges are exclusive of excise, sales, use, property, occupational or like taxes which may be imposed by any taxing authority upon the manufacture, sale or delivery of the items sold hereunder. If any such taxes must be paid by Seller or if Seller is liable for the collection of such tax, the amount thereof shall be in addition to the amounts for the items sold. Buyer agrees to pay all such taxes or to reimburse Seller therefore upon receipt of its invoice. If Buyer claims exemption from any sales, use or other tax imposed by any taxing authority, Buyer shall save Seller harmless from and against any such tax, together with any interest or penalties thereon which may be assessed if the items are held to be taxable.

10. Indemnity For Infringement of Intellectual Property Rights: Seller shall have no liability for infringement of any patents, trademarks, copyrights, trade dress, trade secrets or similar rights except as provided in this Part 10. Seller will defend and indemnify Buyer against allegations of infringement of U.S. Patents, U.S. Trademarks, copyrights, trade dress and trade secrets (hereinafter 'Intellectual Property Rights'). Seller will defend at its expense and will pay the cost of any settlement or damages awarded in an action brought against Buyer based on an allegation that an item sold pursuant to this contract infringes the Intellectual Property Rights of a third party. Seller's obligation to defend and indemnify Buyer is contingent on Buyer notifying Seller within ten (10) days after Buyer becomes aware of such allegations of infringement, and Seller having sole control over the defense of any allegations or actions including all negotiations for settlement or compromise. If an item sold hereunder is subject to a claim that it infringes the Intellectual Property Rights of a third party, Seller may, at its sole expense and option, procure for Buyer the right to continue using said item, replace or modify said item so as to make it noninfringing, or offer to accept return of said item and return the purchase price less a reasonable allowance for depreciation. Notwithstanding the foregoing, Seller shall have no liability for claims of infringement based on information provided by Buyer, or directed to items delivered hereunder for which the designs are specified in whole or part by Buyer, or infringements resulting from the modification, combination or use in a system of any item sold hereunder. The foregoing provisions of this Part 10 shall constitute Seller's sole and exclusive liability and Buyer's sole and exclusive remedy for infringement of Intellectual Property Rights.

If a claim is based on information provided by Buyer or if the design for an item delivered hereunder is specified in whole or in part by Buyer, Buyer shall defend and indemnify Seller for all costs, expenses or judgments resulting from any claim that such item infringes any patent, trademark, copyright, trade dress, trade secret or any similar right.

11. Force Majeure: Seller does not assume the risk of and shall not be liable for delay or failure to perform any of Seller's obligations by reason of circumstances beyond the reasonable control of Seller (hereinafter 'Events of Force Majeure'). Events of Force Majeure shall include without limitation, accidents, acts of God, strikes or labor disputes, acts, laws, rules or regulations of any government or government agency, fires, floods, delays or failures in delivery of carriers or suppliers, shortages of materials and any other cause beyond Seller's control.

12. Entire Agreement/Governing Law: The terms and conditions set forth herein, together with any amendments, modifications and any different terms or conditions expressly accepted by Seller in writing, shall constitute the entire Agreement concerning the items sold, and there are no oral or other representations or agreements which pertain thereto. This Agreement shall be governed in all respects by the law of the State of Ohio. No actions arising out of the sale of the items sold hereunder or this Agreement may be brought by either party more than two (2) years after the cause of action accrues.

11/98-P



Parker Hannifin Corporation
 6035 Parkland Blvd.
 Cleveland, Ohio 44124-4141
 Telephone: (216) 896-3000
 Fax: (216) 896-4000
 www.parker.com

Parker Hannifin Corporation

About Parker Hannifin Corporation

Parker Hannifin is a leading global motion-control company dedicated to delivering premier customer service. A Fortune 500 corporation listed on the New York Stock Exchange (PH), our components and systems comprise over 1,400 product lines that control motion in some 1,000 industrial and aerospace markets. Parker is the only manufacturer to offer its customers a choice of hydraulic, pneumatic, and electromechanical motion-control solutions. Our Company has the largest distribution network in its field, with over 7,500 distributors serving nearly 400,000 customers worldwide.

Parker's Charter

To be a leading worldwide manufacturer of components and systems for the builders and users of durable goods. More specifically, we will design, market and manufacture products controlling motion, flow and pressure. We will achieve profitable growth through premier customer service.

Product Information

North American customers seeking product information, the location of a nearby distributor, or repair services will receive prompt attention by calling the Parker Product Information Center at our toll-free number: 1-800-C-PARKER (1-800-272-7537). In Europe, call 00800-C-PARKER-H (00800-2727-5374).

The Aerospace Group is a leader in the development, design, manufacture and servicing of control systems and components for aerospace and related high-technology markets, while achieving growth through premier customer service.



The Climate & Industrial Controls Group designs, manufactures and markets system-control and fluid-handling components and systems to refrigeration, air-conditioning and industrial customers worldwide.



The Fluid Connectors Group designs, manufactures and markets rigid and flexible connectors, and associated products used in pneumatic and fluid systems.



The Seal Group designs, manufactures and distributes industrial and commercial sealing devices and related products by providing superior quality and total customer satisfaction.



The Hydraulics Group designs, produces and markets a full spectrum of hydraulic components and systems to builders and users of industrial and mobile machinery and equipment.



The Filtration Group designs, manufactures and markets quality filtration and clarification products, providing customers with the best value, quality, technical support, and global availability.



The Automation Group is a leading supplier of pneumatic and electromechanical components and systems to automation customers worldwide.



The Instrumentation Group is a global leader in the design, manufacture and distribution of high-quality critical flow components for worldwide process instrumentation, ultra-high-purity, medical and analytical applications.





Catalog 4200-INST, 20M, WP, 11/04

Parker Hannifin Corporation

Parflex Division
1300 N. Freedom Street
Ravenna, OH 44266-1212
USA
Phone: (330) 296-2871
Fax: (330) 296-1829

Parker Hannifin Corporation

Brass Products Division
300 Parker Drive
Ostego, MI 49078
USA
Phone: (269) 694-9411
Fax: (269) 694-4614

Parker Hannifin Corporation

Parflex Division *polyflex*[®] Operation
12840 Sugar Ridge Boulevard
Stafford, TX 77477
USA
Phone: (281) 530-5300
Fax: (281) 530-5353
www.parker.com