



# Stainless Steel FRLs Air Preparation Units

## Section D



D

### Air Line Filters

- Miniature F504 ..... D2-D3
- Standard F10 ..... D4-D5

### Air Line Coalescing Filters

- Miniature F501 ..... D6-D7
- Standard F11 ..... D8-D9

### Air Line Regulators

- Miniature R354, R364 ..... D10-D11
- Standard R10, R11 ..... D12-D13

### Filter / Regulator

- Miniature B548, B558 ..... D14-D15
- Standard B11, B12 ..... D16-D17

### Air Line Lubricators

- Standard L10 ..... D18-D19



**F504 Filter – Miniature**

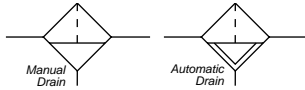

**Features**

- Stainless Steel Construction Handles Most Corrosive Environments
- Fluorocarbon Seals Standard
- Meets NACE Specifications MR-01-75/ISO 15156
- 1/8" Female Threaded Drain
- High Flow: 1/4" - 23 SCFM<sup>§</sup>

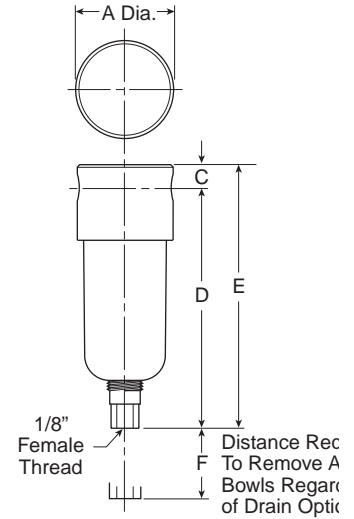

Port Size	NPT	BSPP
	Manual Twist Drain	Manual Twist Drain
1/4"	<b>F504-02DHSS</b>	F504G02DHSS

F504 Filter Dimensions		
<b>A</b>	<b>C</b>	<b>D</b>
1.56 (40)	0.31 (8)	3.69 (94)
<b>E</b>	<b>F</b>	
4.00 (102)	1.58 (40)	

Bold Items are Most Popular.

For other models refer to ordering information below.

<sup>§</sup> SCFM = Standard cubic feet per minute at 90 PSIG inlet and 5 PSIG pressure drop.

inches  
(mm)

**D**

**Ordering Information**

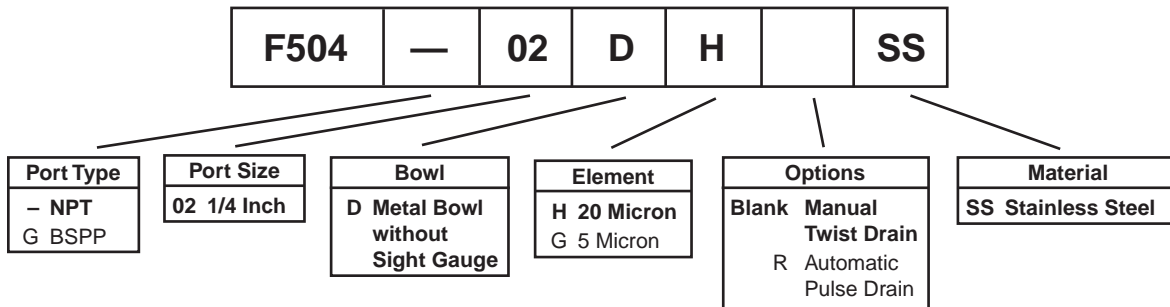

**BOLD ITEMS ARE MOST POPULAR.**

**Operation**

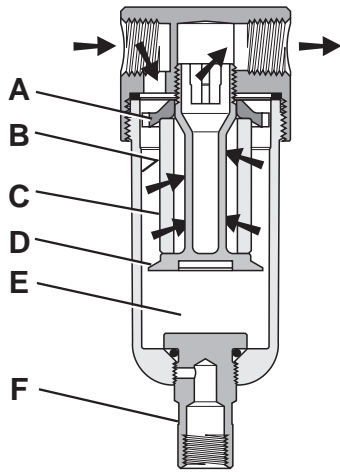

**First Stage Filtration:**

Air enters at inlet port and flows through deflector plate (A) which causes a swirling action. Liquids and coarse particles are forced to the bowl interior wall (B) by the centrifugal action of the swirling air. They are then carried down the bowl wall by the force of gravity. The baffle (D) separates the lower portion of the bowl into a “quiet zone” (E) where the removed liquid and particles collect, unaffected by the swirling air, and are therefore not reentrained into the flowing air.

**Second Stage Filtration:**

After liquids and large particles are removed in the first stages of filtration, the air flows through element (C) where smaller particles are filtered out. The filtered air then passes downstream. Collected liquids and particles in the “quiet zone” (E) should be drained before their level reaches a height where they would be reentrained in the flowing air. This can be accomplished by unscrewing the drain valve (F) slightly until the liquid begins to drain.

**Technical Information**

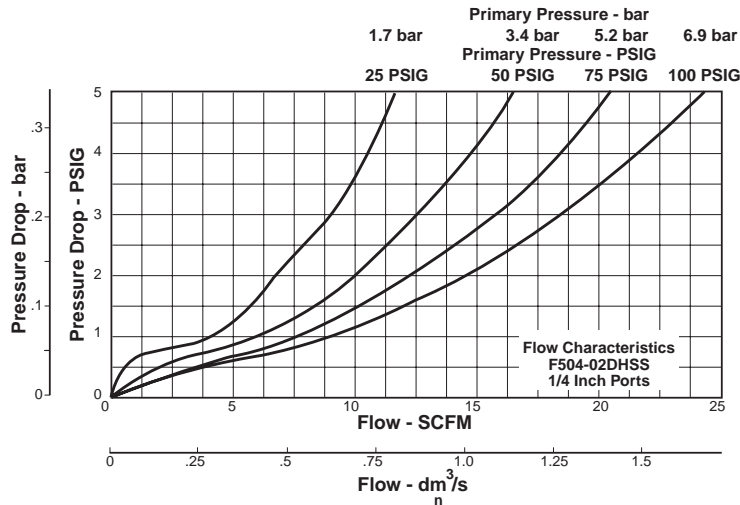

**F504 Filter Kits & Accessories**

- Drain Kits –**
  - Automatic Pulse Drain ..... RK504SY-SS
  - Manual Twist Drain–
    - Small (Old) ..... SA600Y7-1SS
    - Large (New) ..... SAP05481
- Filter Element Kits –**
  - Particulate (5 Micron) ..... EK504VY
  - Particulate (20 Micron) ..... EK504Y
- Pipe Nipple –**
  - 1/4" 316 Stainless Steel ..... 616Y28-SS

**Specifications**

- Bowl Capacity** ..... 1.0 Ounces
- Filter Rating** ..... 20 Micron
- Sump Capacity** ..... 0.4 Ounce
- Port Threads** ..... 1/4 Inch

**Pressure & Temperature Ratings –**

- Manual Twist Drain ..... 0 to 300 PSIG (0 to 20.7 bar)  
0°F to 180°F (-18°C to 82°C)
- Auto Pulse Drain..... 10 to 150 PSIG (0 to 10.3 bar)  
32°F to 150°F (0°C to 66°C)

**Note: Air must be dry enough to avoid ice formation at temperatures below 32°F (0°C).**

**Weight** .....0.6 lb. (0.27 kg)

**Materials of Construction**

- Body** .....316 Stainless Steel
- Bowls** .....316 Stainless Steel
- Deflector** ..... Acetal
- Drain** .....316 Stainless Steel
- Element Holder** ..... Acetal
- Filter Element** ..... Polyethylene
- Seals** ..... Fluorocarbon



**F10 Filter – Standard**

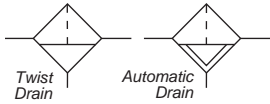

**Features**

- Stainless Steel Construction Handles Most Corrosive Environments
- Meets NACE Specifications MR-01-75/ISO 15156
- 1/8" Female Threaded Drain
- Low Temperature Version Available
- High Flow: 1/2" - 70 SCFM<sup>§</sup>

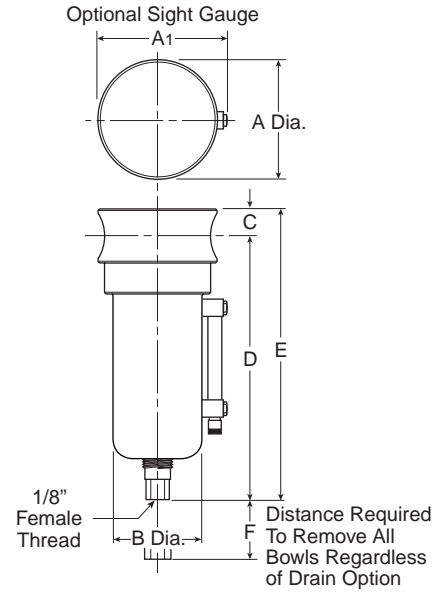

Port Size	NPT		BSPP	
	Manual Twist Drain	Automatic Float Drain	Manual Twist Drain	Automatic Float Drain
1/2"	<b>Metal Bowl With Sight Gauge</b>			
	<b>F10-04WJSS</b>	<b>F10-04WJRSS</b>	F10G04WJSS	F10G04WJRSS

F10 Filter Dimensions		
<b>A</b> 2.38 (60)	<b>A1</b> 2.50 (64)	<b>B</b> 1.75 (44)
<b>C</b> .56 (14)	<b>D</b> 5.00 (127)	<b>E</b> 5.56 (141)
<b>F</b> 2.12 (54)		

**Bold Items are Most Popular.**

For other models refer to ordering information below.

<sup>§</sup> SCFM = Standard cubic feet per minute at 90 PSIG inlet and 5 PSIG pressure drop.

inches  
(mm)

**Ordering Information**

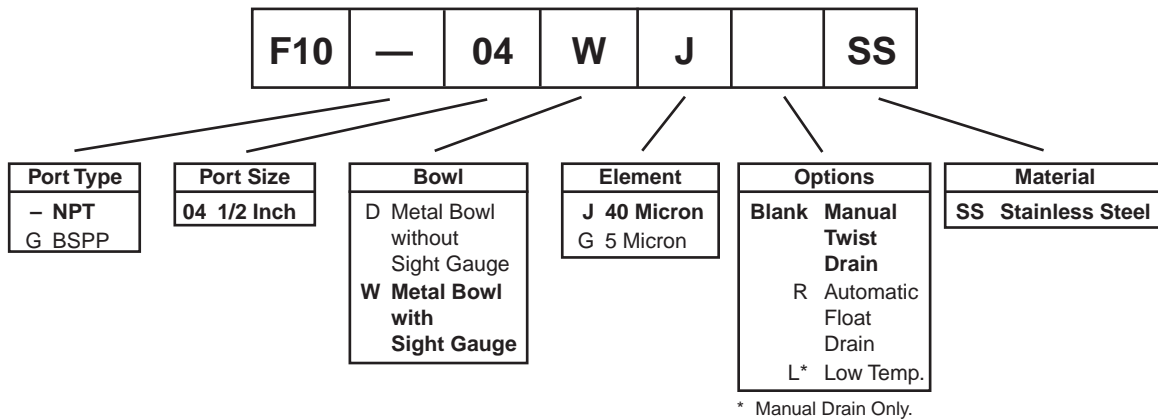

\* Manual Drain Only.

**BOLD ITEMS ARE MOST POPULAR.**

**Technical Specifications – F10**

**Operation**

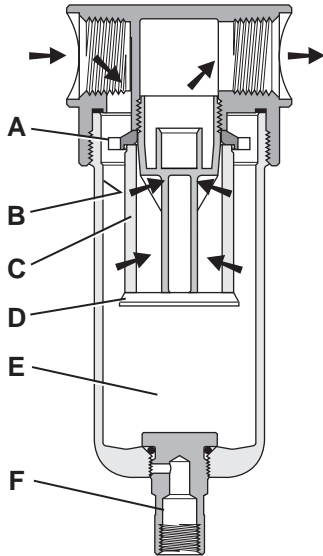

**First Stage Filtration:**

Air enters at inlet port and flows through deflector plate (A) which causes a swirling action. Liquids and coarse particles are forced to the bowl interior wall (B) by the centrifugal action of the swirling air. They are then carried down the bowl wall by the force of gravity. The baffle (D) separates the lower portion of the bowl into a “quiet zone” (E) where the removed liquid and particles collect, unaffected by the swirling air, and are therefore not reentrained into the flowing air.

**Second Stage Filtration:**

After liquids and large particles are removed in the first stages of filtration, the air flows through element (C) where smaller particles are filtered out. The filtered air then passes downstream. Collected liquids and particles in the “quiet zone” (E) should be drained before their level reaches a height where they would be reentrained in the flowing air. This can be accomplished by unscrewing the drain valve (F) slightly until the liquid begins to drain.

**Technical Information**

**\*Note:** “Low Temperature” option is intended for applications where the ambient temperature may be down to -40° C/F. Air supply must be free of moisture to prevent ice formation and malfunction of units. These units contain EPDM seals. Make sure any oils in the airstream are compatible.

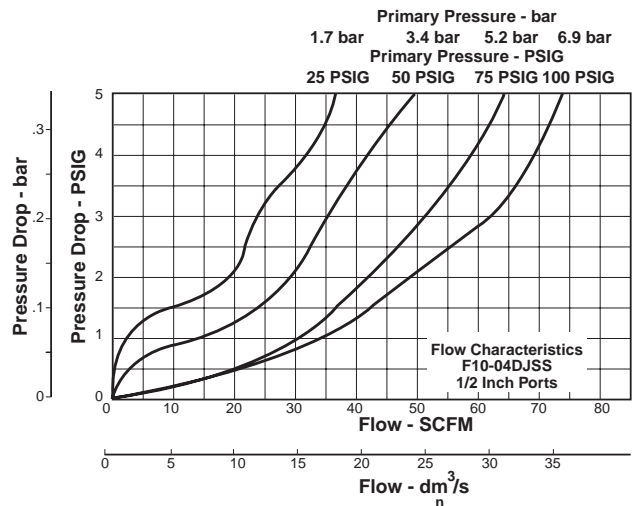

**F10 Filter Kits & Accessories**

**Drain Kits –**

- Automatic Float Drain ..... SA10MDSS
- Manual Twist Drain–
- Small (Old) ..... SA600Y7-1SS
- Large (New) ..... SAP05481

**Filter Element Kits –**

- Particulate (40 Micron) ..... EK55J
- Particulate (5 Micron) ..... EK55G

Pipe Nipple – 1/2" 316 Stainless Steel ..... 616A28-SS

**Specifications**

- Bowl Capacity ..... 4.0 Ounces
- Filter Rating ..... 40 Micron
- Sump Capacity ..... 1.7 Ounce
- Port Threads ..... 1/2 Inch
- Pressure & Temperature Ratings –
- Manual Twist Drain (D) ..... 0 to 300 PSIG (0 to 20.7 bar)  
0°F to 180°F (-18°C to 82°C)

- Manual Twist Drain (W)..... 0 to 250 PSIG (0 to 17.2 bar)  
0°F to 180°F (-18°C to 82°C)
- Automatic Float Drain ..... 15 to 175 PSIG (1 to 12 bar)  
32°F to 150°F (0°C to 66°C)

**Option “L” Minimum Operating Temperature ..... -40° C/F**

**Note: Air must be dry enough to avoid ice formation at temperatures below 32°F (0°C).**

**Weight ..... 1.9 lb. (0.85 kg)**

**Materials of Construction**

- Body .....316 Stainless Steel
- Bowls .....316 Stainless Steel
- Deflector ..... Acetal
- Drain .....316 Stainless Steel
- Element Holder ..... Acetal
- Filter Element ..... Polyethylene
- Seals ..... Fluorocarbon
- Sight Gauge ..... Isoplast



## F501 Coalescing Filter – Miniature



### Features

- Stainless Steel Construction Handles Most Corrosive Environments
- Meets NACE Specifications MR-01-75/ISO 15156
- 1/8" Female Threaded Drain
- High Flow: 1/4" - 16 SCFM<sup>§</sup>

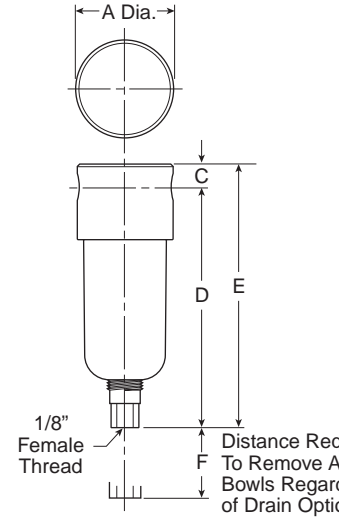

Port Size	NPT	BSPB
	Manual Twist Drain	Manual Twist Drain
1/4"	<b>F501-02DHSS</b>	F501G02DHSS

F501 Coalescing Filter Dimensions		
<b>A</b>	<b>C</b>	<b>D</b>
1.56 (40)	0.31 (8)	3.69 (94)
<b>E</b>	<b>F</b>	
4.00 (102)	1.58 (40)	

**Bold Items are Most Popular.**  
 For other models refer to ordering information below.

<sup>§</sup> SCFM = Standard cubic feet per minute at 90 PSIG inlet and 5 PSIG pressure drop.

inches  
(mm)

### Ordering Information

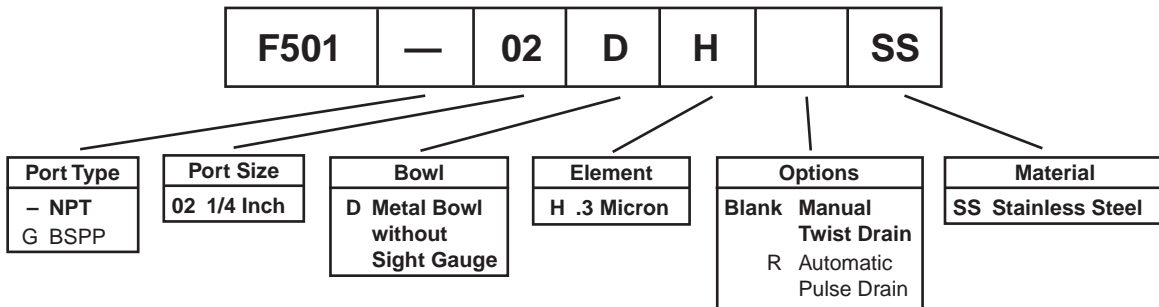

**BOLD ITEMS ARE MOST POPULAR.**

Operation

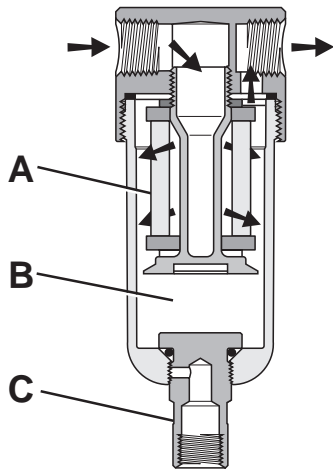

The contaminated air enters the element interior and is forced through a thick membrane (A) of "borosilicate" glass fibers coated with epoxy. Flow then passes through the element, and at this stage 99.97% of the sub micronic particles have been removed from the air stream. The tiny droplets coalesce together and are collected from the filter element by the outer drain layer.

The clean, filtered air now passes through and out into the pneumatic system. The air line coalescing filter removes liquid aerosols and sub-micron particulate matter.

Collected liquids and particles in the "quiet zone" (B) should be drained before their level reaches a height where they would be reentrained in the flowing air. This can be accomplished by unscrewing the drain valve (C) slightly until the liquid begins to drain.

Technical Information

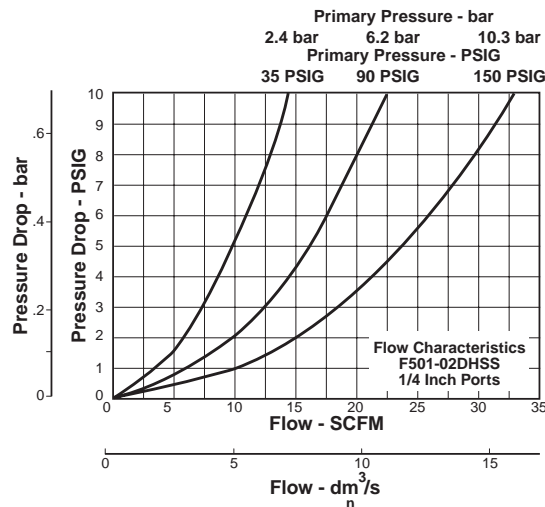

F501 Filter Kits & Accessories

Drain Kits –

- Automatic Pulse Drain ..... RK504SY-SS
- Manual Twist Drain –
- Small (Old) ..... SA600Y7-1SS
- Large (New) ..... SAP05481

Filter Element Kits –

- 0.3 Micron ..... EKF31

Pipe Nipple –

- 1/4" 316 Stainless Steel ..... 616Y28-SS

Specifications

- Bowl Capacity ..... 1.0 Ounces
- Filter Rating ..... 0.3 Micron
- Sump Capacity ..... 0.4 Ounce
- Port Threads ..... 1/4 Inch

Pressure & Temperature Ratings –

- Manual Twist Drain ..... 0 to 300 PSIG (0 to 20.7 bar)  
0°F to 180°F (-18°C to 82°C)
- Auto Pulse Drain ..... 10 to 150 PSIG (0 to 10.3 bar)  
32°F to 150°F (0°C to 66°C)

Note: Air must be dry enough to avoid ice formation at temperatures below 32°F (0°C).

Weight ..... 0.6 lb. (0.27 kg)

Materials of Construction

- Body ..... 316 Stainless Steel
- Bowls ..... 316 Stainless Steel
- Drain ..... 316 Stainless Steel
- Element Holder ..... Acetal
- Filter Element ..... Borosilicate Fiber
- Seals ..... Fluorocarbon



## F11 Coalescing Filter – Standard

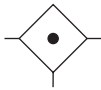

### Features

- Stainless Steel Construction Handles Most Corrosive Environments
- Meets NACE Specifications MR-01-75/ISO 15156
- 1/8" Female Threaded Drain
- Low Temperature Version Available
- High Flow: 1/2" - 45 SCFM<sup>§</sup>

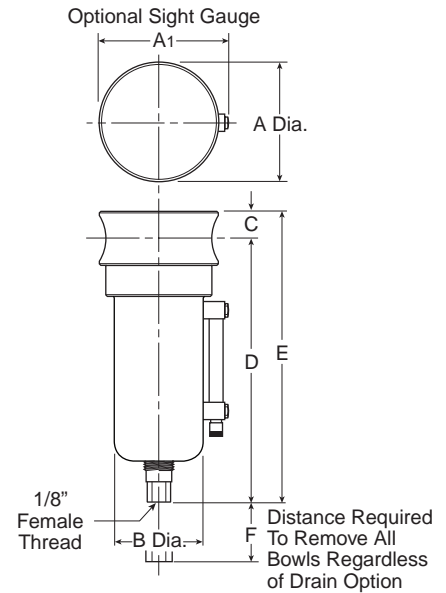

Port Size	NPT		BSPP	
	Manual Twist Drain	Automatic Float Drain	Manual Twist Drain	Automatic Float Drain
1/2"	<b>Metal Bowl With Sight Gauge</b>			
	<b>F11-04WJSS</b>	<b>F11-04WJRSS</b>	F11G04WJSS	F11G04WJRSS

F11 Coalescing Filter Dimensions		
<b>A</b> 2.38 (60)	<b>A1</b> 2.50 (64)	<b>B</b> 1.75 (44)
<b>C</b> 0.56 (14)	<b>D</b> 5.00 (127)	<b>E</b> 5.56 (141)
<b>F</b> 2.12 (54)		

**Bold Items are Most Popular.**

For other models refer to ordering information below.

<sup>§</sup> SCFM = Standard cubic feet per minute at 90 PSIG inlet and 5 PSIG pressure drop.

inches  
(mm)

### Ordering Information

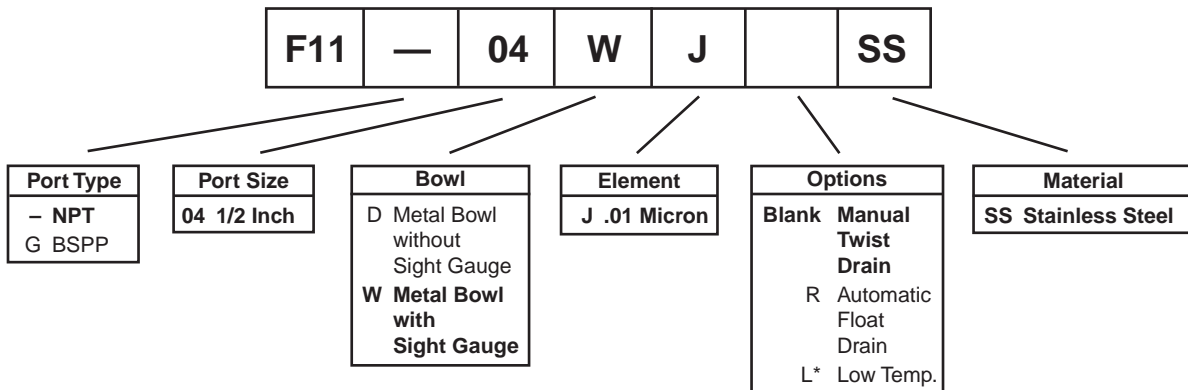

\* Manual Drain Only.

**BOLD ITEMS ARE MOST POPULAR.**



**Miniature R354, R364 Series**

**R354, R364 Regulator – Miniature**

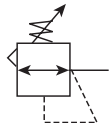

**Features**

- Stainless Steel Construction Handles Most Corrosive Environments
- Large Diaphragm to Valve Area Ratio for Precise Regulation and High Flow Capacity
- Meets NACE Specifications MR-01-75/ISO 15156
- High Flow: 1/4" – 12 SCFM<sup>§</sup>



R364



R354

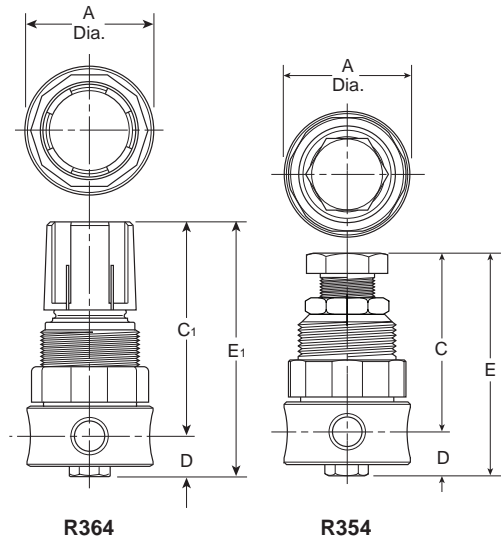

Series	Adjustment Type	Port Size	NPT	BSPP
R364	Knob	1/4"	<b>R364-02CSS</b>	R364G02CSS
R354	All Metal	1/4"	<b>R354-02CSS</b>	R354G02CSS

R354, R364 Regulator Dimensions		
A	C	C <sub>1</sub>
1.56 (40)	2.00 (51)	2.56 (65)
D	E	E <sub>1</sub>
0.50 (13)	2.50 (64)	3.06 (78)

Standard part numbers shown bold. For other models refer to ordering information below.

<sup>§</sup> SCFM = Standard cubic feet per minute at 100 PSIG inlet, 75 PSIG no flow secondary setting and 15 PSIG pressure drop.

inches (mm)  
NOTE: 1.25 Dia. (32mm) hole required for panel mounting.

**⚠ WARNING**

Product rupture can cause serious injury.  
Do not connect regulator to bottled gas.  
Do not exceed maximum primary pressure rating.

**Ordering Information**

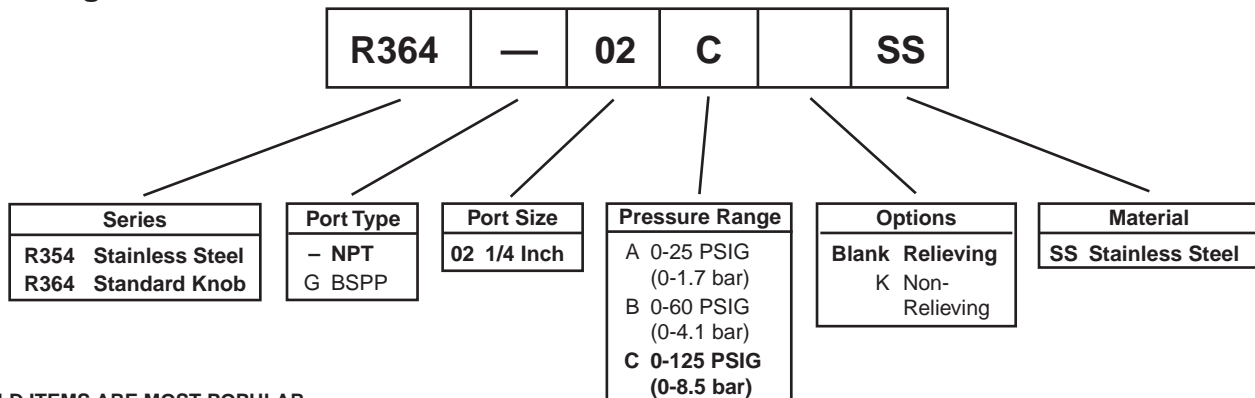

BOLD ITEMS ARE MOST POPULAR.



**Operation**

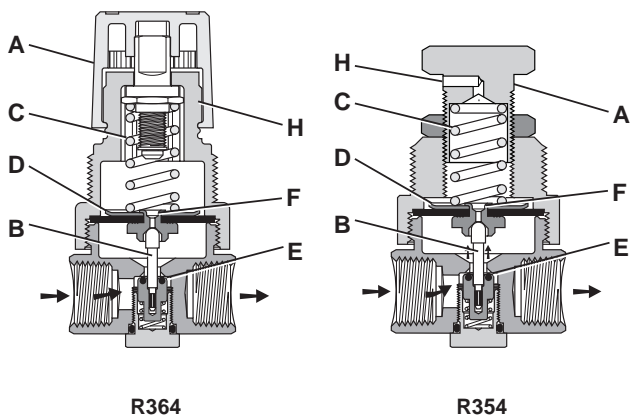

With the adjusting knob (A) turned fully counter-clockwise (no spring load), and pressure supplied to the regulator inlet port, the valve poppet assembly (B) is closed. Turning the adjusting knob clockwise applies a load to control spring (C). This load causes the diaphragm (D) and the valve poppet assembly (B) to move downward allowing flow across the seat area (E) created between the poppet assembly and the seat. Pressure in the downstream line is sensed below the diaphragm (D) and offsets the load of spring (C). As downstream pressure rises, poppet assembly (B) and diaphragm (D) move upward until the area (E) is closed and the load of the spring (C) and pressure under diaphragm (D) are in balance. A reduced outlet pressure has now been obtained, depending on spring load. Creating a demand downstream, such as opening a valve, results in a reduced pressure under the diaphragm (D). The load of control spring (C) now causes the poppet assembly to move downward opening seat area (E) allowing air to flow to meet the downstream demand. The flow of downstream air is metered by the amount of opening (E).

Should downstream pressure exceed the desired regulated pressure, the excess pressure will cause the diaphragm (D) to move upward against control spring (C), open vent hole (F), and vent the excess pressure to atmosphere through the hole in the bonnet (H). (This occurs in the relieving type regulator only.)

**Technical Information**

**CAUTION:**

**REGULATOR PRESSURE ADJUSTMENT –**

The working range of knob adjustment is designed to permit outlet pressures within their full range. Pressure adjustment beyond this range is also possible because the knob is not a limiting device. This is a common characteristic of most industrial regulators, and limiting devices may be obtained only by special design.

For best performance, regulated pressure should always be set by increasing the pressure up to the desired setting.

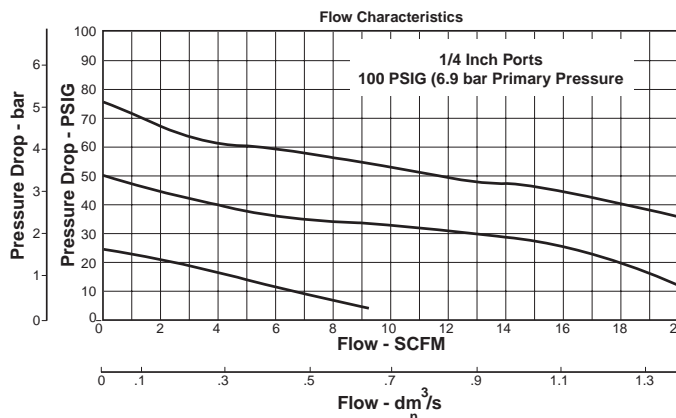

**R354, R364 Regulator Kits & Accessories**

- R354 Bonnet Kit .....CKR354YSS
- R364 Bonnet Kit (Knob Included) .....CKR364YSS
- Gauge –
  - 160 PSIG (0 to 1100 kPa) .....K4515N14160SS
- Panel Mount Bracket (Stainless) ..... 161X57-SS
- Panel Mount Nut –
  - Stainless ..... R05X51-SS
  - Plastic.....R05X51-P
- Pipe Nipple –
  - 1/4" 316 Stainless Steel ..... 616Y28-SS
- Service Kit –
  - Relieving .....RKR364YSS
  - Non-Relieving..... RKR364KYSS
- Springs –
  - 0-25 PSIG Range .....SPR-375-2-SS
  - 0-60 PSIG Range .....SPR-376-1-SS
  - 0-125 PSIG Range.....SPR-377-1-SS

**Specifications**

- Gauge Port .....1/4 Inch
- Operation .....Fluorocarbon Diaphragm
- Port Threads .....1/4 Inch
- Pressure & Temperature Ratings – ..... 300 PSIG Max (20.7 bar)  
0°F to 180°F (-18°C to 82°C)
- Note: Air must be dry enough to avoid ice formation at temperatures below 32°F (0°C).
- Weight .....0.5 lb. (0.23 kg)

**Materials of Construction**

- Adjustment Mechanism / Springs .....316 Stainless Steel
- Adjusting Knob (R354).....316 Stainless Steel
- Adjusting Knob (R364) ..... Polypropylene
- Body .....316 Stainless Steel
- Bonnet (R354) .....316 Stainless Steel
- Bonnet (R364) ..... Acetal
- Bottom Plug .....316 Stainless Steel
- Poppet .....316 Stainless Steel
- Seals ..... Fluorocarbon



**Standard R10, R11 Series**

**R10, R11 Regulator – Standard**

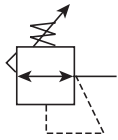

**Features**

- Stainless Steel Construction Handles Most Corrosive Environments
- Large Daphragm to Valve Area Ratio for Precise Regulation and High Flow Capacity
- Meets NACE Specifications MR-01-75/ISO 15156
- Low Temperature Version Available
- High Flow: 1/2" – 80 SCFM<sup>§</sup>



R11



R10

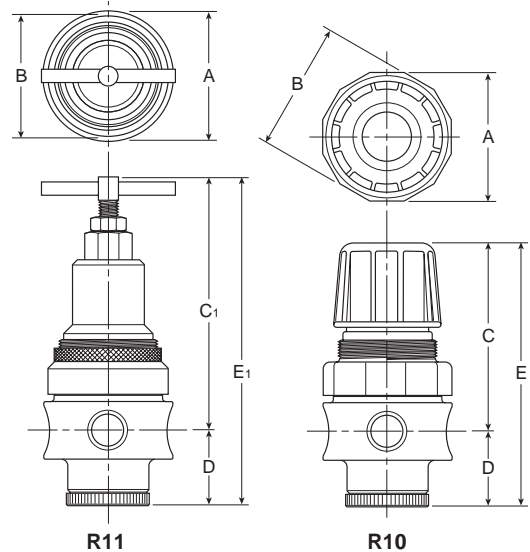

Series	Adjustment Type	Port Size	NPT	BSPP
R10	Knob	1/2"	<b>R10-04CSS</b>	R10G04CSS
R11	Tee Handle	1/2"	<b>R11-04CSS</b>	R11G04CSS

R10, R11 Regulator Dimensions		
<b>A</b> 2.34 (60)	<b>B</b> 2.43 (62)	<b>C</b> 3.59 (91)
<b>C<sub>1</sub></b> 4.70 (119)	<b>D</b> 1.38 (35)	<b>E</b> 4.97 (126)
<b>E<sub>1</sub></b> 6.08 (154)		

Standard part numbers shown bold. For other models refer to ordering information below.

<sup>§</sup> SCFM = Standard cubic feet per minute at 100 PSIG inlet, 75 PSIG no flow secondary setting and 15 PSIG pressure drop.

**⚠ WARNING**

**Product rupture can cause serious injury.  
Do not connect regulator to bottled gas.  
Do not exceed maximum primary pressure rating.**

inches (mm)  
NOTE: 1.75 Dia. (44mm) hole required for panel mounting.

**Ordering Information**

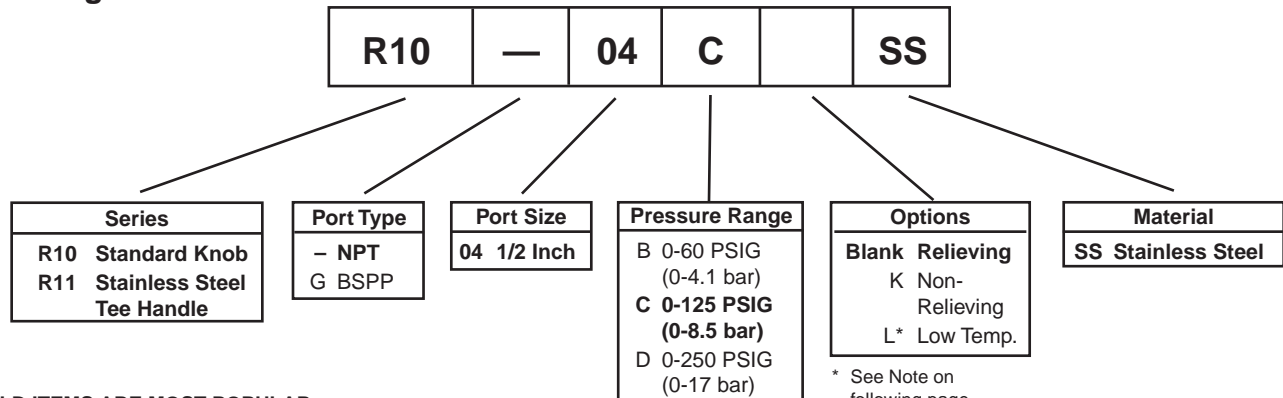

**BOLD ITEMS ARE MOST POPULAR.**



**Operation**

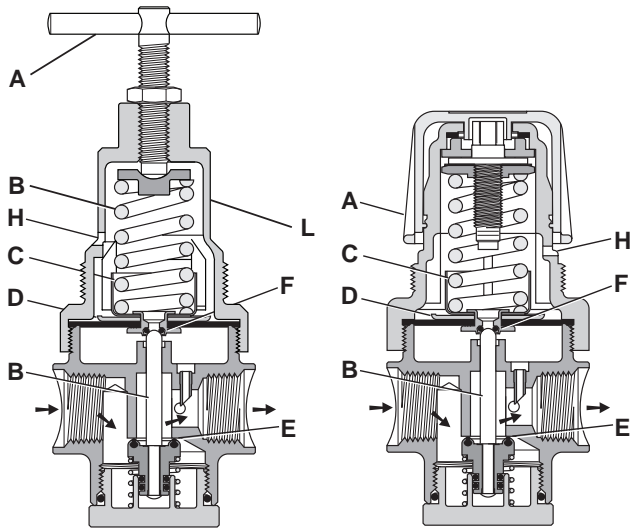

With the adjusting knob / Tee Handle (A) turned fully counter-clockwise (no spring load), and pressure supplied to the regulator inlet port, the valve poppet assembly (B) is closed. Turning the adjusting knob clockwise applies a load to control spring (C). This load causes the diaphragm (D) and the valve poppet assembly (B) to move downward allowing flow across the seat area (E) created between the poppet assembly and the seat. Pressure in the downstream line is sensed below the diaphragm (D) and offsets the load of spring (C). As downstream pressure rises, poppet assembly (B) and diaphragm (D) move upward until the area (E) is closed and the load of the spring (C) and pressure under diaphragm (D) are in balance. A reduced outlet pressure has now been obtained, depending on spring load. Creating a demand downstream, such as opening a valve, results in a reduced pressure under the diaphragm (D). The load of control spring (C) now causes the poppet assembly to move downward opening seat area (E) allowing air to flow to meet the downstream demand. The flow of downstream air is metered by the amount of opening (E). Should downstream pressure exceed the desired regulated pressure, the excess pressure will cause the diaphragm (D) to move upward against control spring (C), open vent hole (F), and vent the excess pressure to atmosphere through the hole in the bonnet (H). (This occurs in the relieving type regulator only.)

**Technical Information**

**CAUTION:**

**REGULATOR PRESSURE ADJUSTMENT –**

The working range of knob adjustment is designed to permit outlet pressures within their full range. Pressure adjustment beyond this range is also possible because the knob is not a limiting device. This is a common characteristic of most industrial regulators, and limiting devices may be obtained only by special design.

For best performance, regulated pressure should always be set by increasing the pressure up to the desired setting.

\* **Note:** “Low Temperature” option is intended for applications where the ambient temperature may be down to -40° C/F. Air supply must be free of moisture to prevent ice formation and malfunction of units. These units contain EPDM seals. Make sure any oils in the airstream are compatible.

**R10, R11 Regulator Kits & Accessories**

R10 Bonnet Kit (Knob Included) .....	CKR10YSS
R11 Bonnet Kit.....	CKR11YSS
<b>Gauge –</b>	
160 PSIG (0 to 1100 kPa), 2" Face .....	K4520N14160SS
<b>Panel Mount Bracket (Stainless) .....</b>	R10Y57-SS
<b>Panel Mount Nut –</b>	
Stainless .....	R10X51-SS
Plastic.....	R10X51-P
<b>Pipe Nipple –</b>	
1/2" 316 Stainless Steel .....	616A28-SS
<b>Service Kit –</b>	
Relieving.....	RKR10YSS
Non-Relieving.....	RKR10KYSS
<b>Springs –</b>	
0-60 PSIG Range .....	SPR-388-1-SS
0-125 PSIG Range .....	SPR-389-1-SS
0-250 PSIG Range .....	SPR-390-1-SS

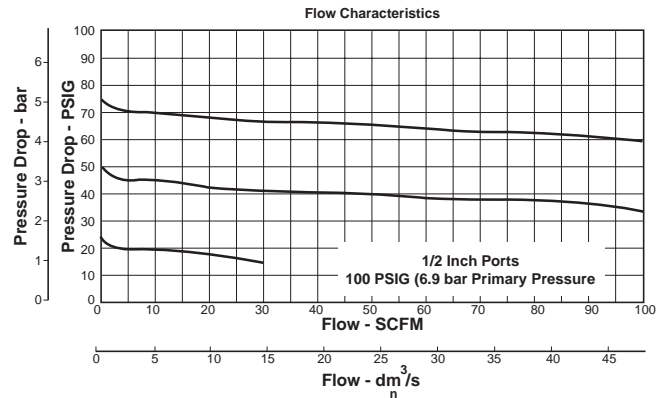

**Specifications**

Gauge Port .....	1/4 Inch
Operation .....	Fluorocarbon Diaphragm
Port Threads .....	1/2 Inch
Pressure & Temperature Ratings – .....	300 PSIG Max (20.7 bar)
	0°F to 180°F (-18°C to 82°C)
Option “L” Minimum Operating Temperature .....	-40° C/F

**Note:** Air must be dry enough to avoid ice formation at temperatures below 32°F (0°C).

**Weight** ..... 1.79 lb. (0.81 kg)

**Materials of Construction**

Adjustment Mechanism / Springs .....	316 Stainless Steel
Body .....	316 Stainless Steel
Bonnet / Tee Handle (R11).....	316 Stainless Steel
Bonnet / Knob (R10) .....	Acetal
Bottom Plug .....	316 Stainless Steel
Poppet .....	316 Stainless Steel
Seals .....	Fluorocarbon



**Miniature B548, B558 Series**

**B548, B558 Filter / Regulator – Miniature**

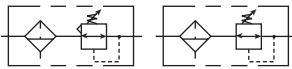

**Features**

- Stainless Steel Construction Handles Most Corrosive Environments
- Large Diaphragm to Valve Area Ratio for Precise Regulation and High Flow Capacity
- 1/8" Female Threaded Drain
- Meets NACE Specifications MR-01-75/ISO 15156.
- High Flow: 1/4" – 12 SCFM<sup>§</sup>



**B548**



**B558**

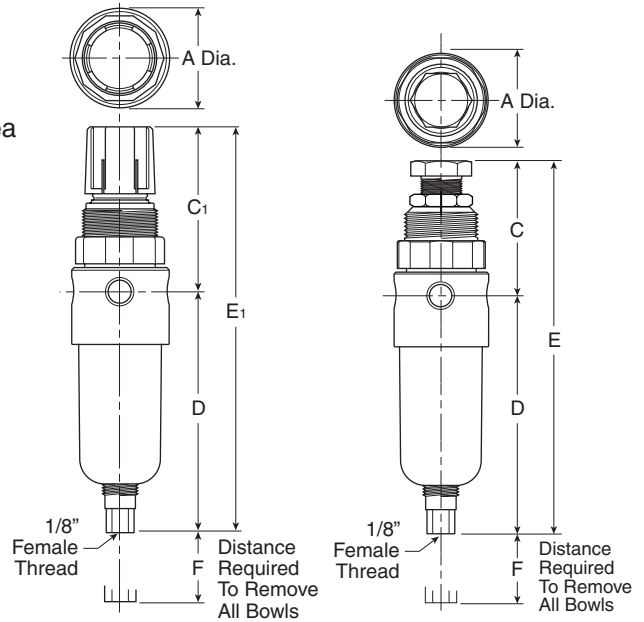

Series	Adjustment Type	Port Size	NPT	BSP
B548	Knob	1/4"	<b>B548-02DHCSS</b>	B548G02DHCSS
B558	All Metal	1/4"	<b>B558-02DHCSS</b>	B558G02DHCSS

B548, B558 Piggyback Dimensions		
<b>A</b> 1.56 (40)	<b>C</b> 2.17 (55)	<b>C<sub>1</sub></b> 2.63 (67)
<b>D</b> 3.63 (92)	<b>E</b> 5.80 (147)	<b>E<sub>1</sub></b> 6.26 (159)
<b>F</b> 1.58 (40)		

Standard part numbers shown bold. For other models refer to ordering information below.

<sup>§</sup> SCFM = Standard cubic feet per minute at 100 PSIG inlet, 75 PSIG no flow secondary setting and 15 PSIG pressure drop.

**⚠ WARNING**

**Product rupture can cause serious injury.  
Do not connect regulator to bottled gas.  
Do not exceed maximum primary pressure rating.**

inches (mm)  
NOTE: 1.25 Dia. (32mm) hole required for panel mounting.

**Ordering Information**

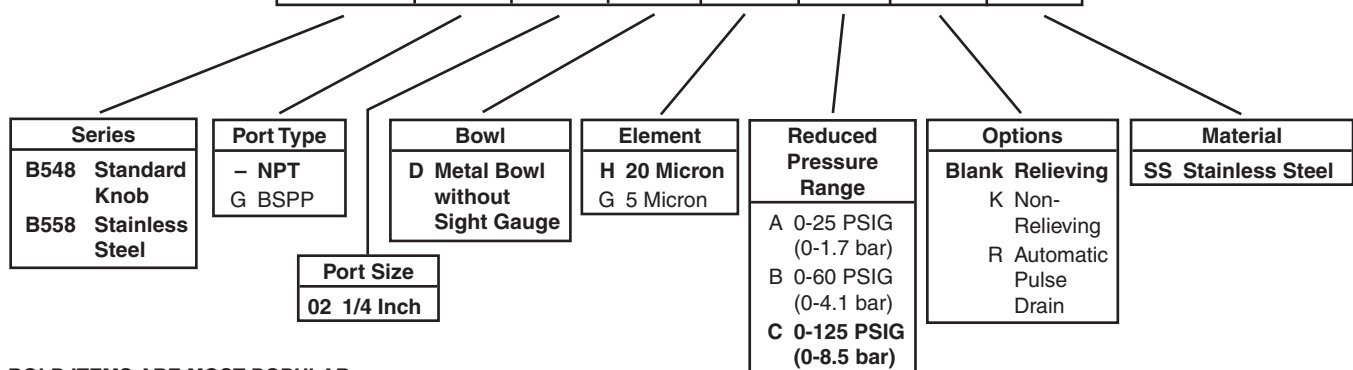

**BOLD ITEMS ARE MOST POPULAR.**



**Operation**

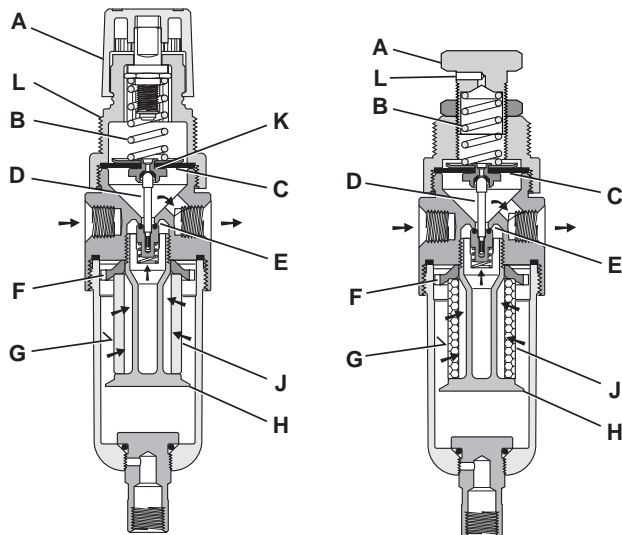

Turning the adjusting knob (A) clockwise applies a load to control spring (B) which forces diaphragm (C) and valve poppet assembly (D) to move downward allowing filtered air to flow through the seat area (E) created between the poppet assembly and the seat. “**First stage filtration**”. Air pressure supplied to the inlet port is directed through deflector plate (F) causing a swirling centrifugal action forcing liquids and coarse particles to the inner bowl wall (G) and down below the lower baffle (H) to the quiet zone. After liquids and large particles are removed in the first stage of filtration “**second stage filtration**” occurs as air flows through element (J) where smaller particles are filtered out and retained. The air flow now passes through seat area (E) to the outlet port of the unit. Pressure in the downstream line is sensed below the diaphragm (C) and offsets the load of spring (B). When downstream pressure reaches the set-point, poppet valve assembly (D) and diaphragm (C) move upward closing seat area (E). Should downstream pressure exceed the desired regulated pressure, the excess pressure will cause the diaphragm (C) to move upward opening vent hole (K) venting the excess pressure to atmosphere through the hole in the bonnet (L). (This occurs in the standard relieving type filter/regulators only.)

**Technical Information**

**CAUTION:**

**REGULATOR PRESSURE ADJUSTMENT** – The working range of knob adjustment is designed to permit outlet pressures within their full range. Pressure adjustment beyond this range is also possible because the knob is not a limiting device. This is a common characteristic of most industrial regulators, and limiting devices may be obtained only by special design.

For best performance, regulated pressure should always be set by increasing the pressure up to the desired setting.

**B548, B558 Regulator Kits & Accessories**

- B558 Bonnet Kit (Knob Included) .....CKR354YSS
- B548 Bonnet Kit (Knob Included) .....CKR364YSS
- Drain Kit –**
- Automatic Pulse Drain ..... RK504SY-SS
- Manual Twist Drain – ..... SA600Y7-1SS
- Filter Element Kits –**
- Particulate (5 Micron) ..... EK504VY
- Particulate (20 Micron) ..... EK504Y
- Gauge –**
- 160 PSIG (0 to 1100 kPa), 2" Face .....K4515N14160SS
- Panel Mount Bracket (Stainless)..... 161X57-SS**
- Panel Mount Nut –**
- Stainless ..... R05X51-SS
- Plastic.....R05X51-P
- Pipe Nipple –**
- 1/4" 316 Stainless Steel ..... 616Y28-SS
- Service Kit –**
- Relieving ..... RK549YSS
- Non-Relieving..... RK548YSS
- Springs –**
- 0-25 PSIG Range ..... SPR-375-2-SS
- 0-60 PSIG Range ..... SPR-376-1-SS
- 0-125 PSIG Range ..... SPR-377-1-SS

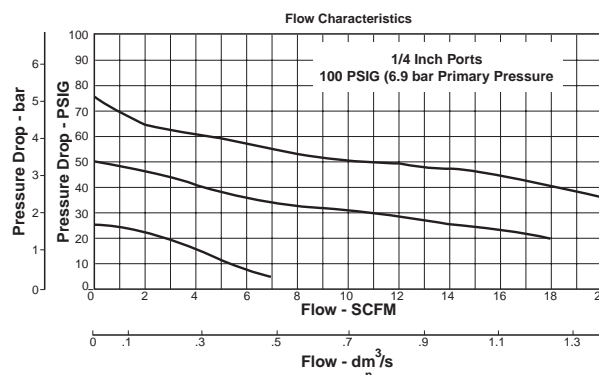

**Specifications**

- Bowl Capacity** ..... 1.0 Ounces
- Filter Rating** .....20 Micron
- Gauge Port** ..... 1/4 Inch
- Operation** ..... Fluorocarbon Diaphragm
- Port Threads** ..... 1/4 Inch
- Pressure & Temperature Ratings –**
- Manual Twist Drain ..... 0 to 300 PSIG (0 to 20.7 bar)
- 0°F to 180°F (-18°C to 82°C)
- Auto Pulse Drain..... 10 to 150 PSIG (0 to 10.3 bar)
- 32°F to 150°F (0°C to 66°C)
- Note: Air must be dry enough to avoid ice formation at temperatures below 32°F (0°C).**
- Sump Capacity** .....0.4 Ounce
- Weight** .....0.6 lb. (0.27 kg)

**Materials of Construction**

- Adjustment Mechanism / Springs** .....316 Stainless Steel
- Body** .....316 Stainless Steel
- Bonnet (B548)** ..... Acetal
- Bonnet (B558)** .....316 Stainless Steel
- Bottom Plug** .....316 Stainless Steel
- Knob (B548)** ..... Polypropylene
- Knob (B558)** .....316 Stainless Steel
- Poppet** .....316 Stainless Steel
- Seals** ..... Fluorocarbon



**B11, B12 Filter / Regulator – Standard**

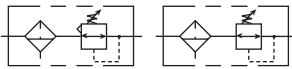

B12

B11

**Features**

- Stainless Steel Construction Handles Most Corrosive Environments
- Large Diaphragm to Valve Area Ratio for Precise Regulation and High Flow Capacity
- 1/8" Female Threaded Drain
- Meets NACE Specifications MR-01-75/ISO-15156
- Low Temperature Version Available
- High Flow: 1/2" – 72 SCFM<sup>§</sup>

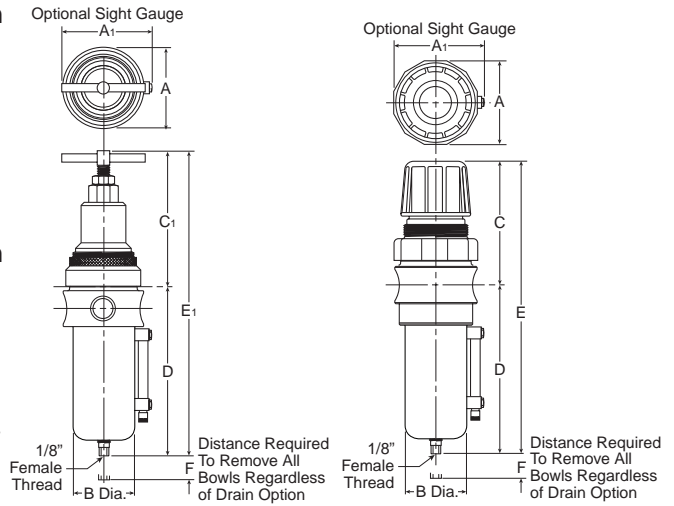

B12

B11

Series	Adjustment Type	Port Size	NPT		BSPP	
			Manual Twist Drain	Automatic Float Drain	Manual Twist Drain	Automatic Float Drain
<b>Metal Bowl with Sight Gauge</b>						
B11	Knob	1/2"	<b>B11-04WJCSS</b>	<b>B11-04WJCRSS</b>	B11G04WJCSS	B11G04WJCRSS
B12	Tee-Handle	1/2"	<b>B12-04WJCSS</b>	<b>B12-04WJCRSS</b>	B12G04WJCSS	B12G04WJCRSS

B11, B12 Piggyback Dimensions		
<b>A</b> 2.34 (60)	<b>A1</b> 2.50 (64)	<b>B</b> 1.75 (44)
<b>C</b> 3.59 (91)	<b>C1</b> 4.70 (119)	<b>D</b> 5.00 (127)
<b>E</b> 8.59 (218)	<b>E1</b> 9.70 (246)	<b>F</b> 2.12 (54)

Standard part numbers shown bold. For other models refer to ordering information below.

<sup>§</sup> SCFM = Standard cubic feet per minute at 100 PSIG inlet, 90 PSIG no flow secondary setting and 15 PSIG pressure drop.

inches (mm)  
NOTE: 1.75 Dia. (44mm) hole required for panel mounting.

**⚠ WARNING**

Product rupture can cause serious injury.  
Do not connect regulator to bottled gas.  
Do not exceed maximum primary pressure rating.

**Ordering Information**

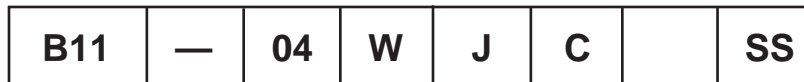

Series	Port Type	Bowl	Element	Reduced Pressure Range	Options	Material
B11 Standard Knob B12 Stainless Steel	- NPT G BSPP	D Metal Bowl without Sight Gauge W Metal Bowl with Sight Gauge	J 40 Micron G 5 Micron	B 0-60 PSIG (0-4.1 bar) C 0-125 PSIG (0-8.5 bar) D 0-250 PSIG (0-17 bar)	Blank Relieving K Non-Relieving R Automatic Float Drain L* Low Temp. <small>* Manual Drain Only.</small>	SS Stainless Steel

BOLD ITEMS ARE MOST POPULAR.



**Operation**

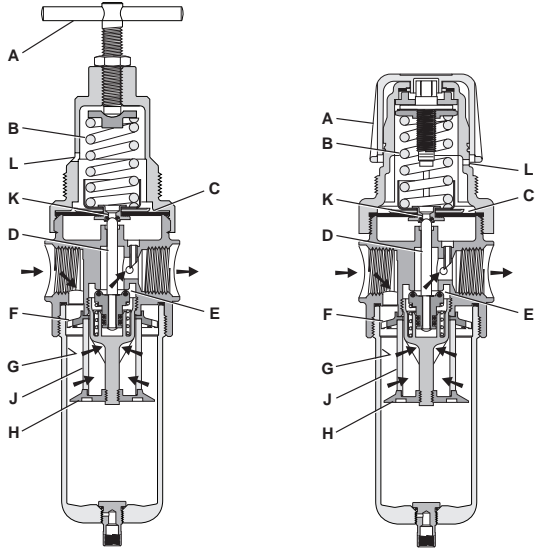

Turning the adjusting knob / Tee Handle (A) clockwise applies a load to control spring (B) which forces diaphragm (C) and valve poppet assembly (D) to move downward allowing filtered air to flow through the seat area (E) created between the poppet assembly and the seat. "First stage filtration".

Air pressure supplied to the inlet port is directed through deflector plate (F) causing a swirling centrifugal action forcing liquids and coarse particles to the inner bowl wall (G) and down below the lower baffle (H) to the quiet zone. After liquids and large particles are removed in the first stage of filtration "second stage filtration" occurs as air flows through element (J) where smaller particles are filtered out and retained. The air flow now passes through seat area (E) to the outlet port of the unit. Pressure in the downstream line is sensed below the diaphragm (C) and offsets the load of spring (B). When downstream pressure reaches the set-point, poppet valve assembly (D) and diaphragm (C) move upward closing seat area (E). Should downstream pressure exceed the desired regulated pressure, the excess pressure will cause the diaphragm (C) to move upward opening vent hole (K) venting the excess pressure to atmosphere through the hole in the bonnet (L). (This occurs in the standard relieving type filter/regulators only.)

**Technical Information**

**CAUTION:**

**REGULATOR PRESSURE ADJUSTMENT** – The working range of knob adjustment is designed to permit outlet pressures within their full range. Pressure adjustment beyond this range is also possible because the knob is not a limiting device. This is a common characteristic of most industrial regulators, and limiting devices may be obtained only by special design.

For best performance, regulated pressure should always be set by increasing the pressure up to the desired setting.

\*Note: "Low Temperature" option is intended for applications where the ambient temperature may be down to -40° C/F. Air supply must be free of moisture to prevent ice formation and malfunction of units. These units contain EPDM seals. Make sure any oils in the airstream are compatible.

**B11, B12 Regulator Kits & Accessories**

- B11 Bonnet Kit (Knob Included) .....CKR10YSS
- B12 Bonnet Kit .....CKR11YSS
- Drain Kit –
  - Automatic Float Drain ..... SA10MDSS
  - Manual Twist Drain ..... SA600Y7-1SS
- Filter Element Kits –
  - Particulate (40 Micron) ..... EKF10Y
  - Particulate (5 Micron) ..... EKF10VY
- Gauge –
  - 160 PSIG (0 to 1100 kPa), 2" Face .....K4520N14160SS
- Panel Mount Bracket (Stainless) ..... R10Y57-SS
- Panel Mount Nut –
  - Stainless ..... R10X51-SS
  - Plastic ..... R10X51-P
- Pipe Nipple –
  - 1/2" 316 Stainless Steel ..... 616A28-SS
- Service Kit –
  - Relieving ..... RKR10YSS
  - Non-Relieving ..... RKR10KYSS
- Springs –
  - 0-60 PSIG Range ..... SPR-388-1-SS
  - 0-125 PSIG Range ..... SPR-389-1-SS
  - 0-250 PSIG Range ..... SPR-390-1-SS

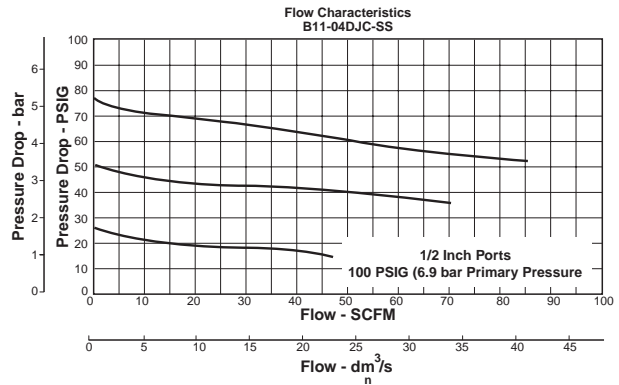

**Specifications**

- Bowl Capacity ..... 4.0 Ounces
- Filter Rating ..... 40 Micron
- Gauge Port ..... 1/4 Inch
- Operation ..... Fluorocarbon Diaphragm
- Port Threads ..... 1/2 Inch
- Pressure & Temperature Ratings –
  - Metal Bowl (D) ..... 300 PSIG Max (20.7 bar)
  - 0°F to 180°F (-18°C to 82°C)
  - Metal Bowl (W) ..... 0 to 250 PSIG (0 to 17.2 bar)
  - 0°F to 180°F (-18°C to 82°C)
  - Automatic Float Drain ..... 15 to 175 PSIG (1 to 12 bar)
  - 32°F to 150°F (0°C to 66°C)
- Option "L" Minimum Operating Temperature ..... -40° C/F

Note: Air must be dry enough to avoid ice formation at temperatures below 32°F (0°C).

- Sump Capacity ..... 1.7 Ounce
- Weight ..... 2.42 lb. (1.09 kg)

**Materials of Construction**

- Adjustment Mechanism / Springs ..... 316 Stainless Steel
- Body ..... 316 Stainless Steel
- Bonnet / Knob (B11) ..... Acetal
- Bonnet / Tee Handle (B12) ..... 316 Stainless Steel
- Bottom Plug ..... 316 Stainless Steel
- Poppet ..... 316 Stainless Steel
- Seals ..... Fluorocarbon
- Sight Gauge ..... Isoplast



**L10 Lubricator – Standard**

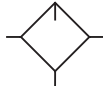

**Features**

- Stainless Steel Construction Handles Most Corrosive Environments
- 1/8" Female Threaded Drain
- Fillable Under Pressure
- Meets NACE Specifications MR-01-75/ISO 15156
- High Flow: 1/2" - 100 SCFM<sup>§</sup>

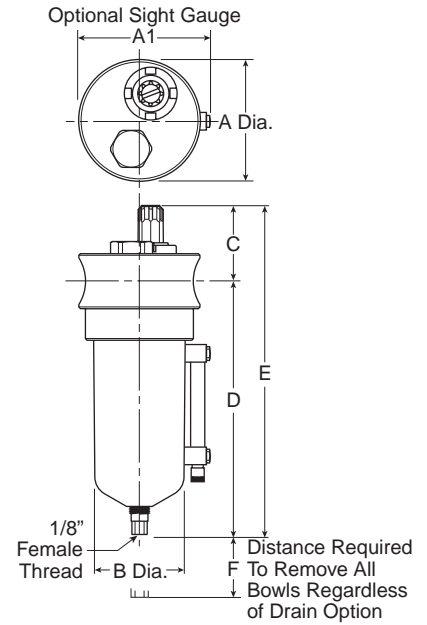

<b>Port Size</b>	<b>NPT</b>	<b>BSPB</b>
	<b>Manual Twist Drain</b>	<b>Manual Twist Drain</b>
1/2"	<b>Metal Bowl With Sight Gauge</b>	
	<b>L10-04WSS</b>	L10G04WSS

<b>L10 Lubricator Dimensions</b>		
<b>A</b> 2.38 (60)	<b>A1</b> 2.50 (64)	<b>B</b> 1.75 (44)
<b>C</b> 1.81 (46)	<b>D</b> 5.00 (127)	<b>E</b> 6.81 (173)
<b>F</b> 3.50 (89)		

**Bold Items are Most Popular.**

For other models refer to ordering information below.

<sup>§</sup> SCFM = Standard cubic feet per minute at 90 PSIG inlet, and 5 PSIG pressure drop.

inches  
(mm)

**Ordering Information**

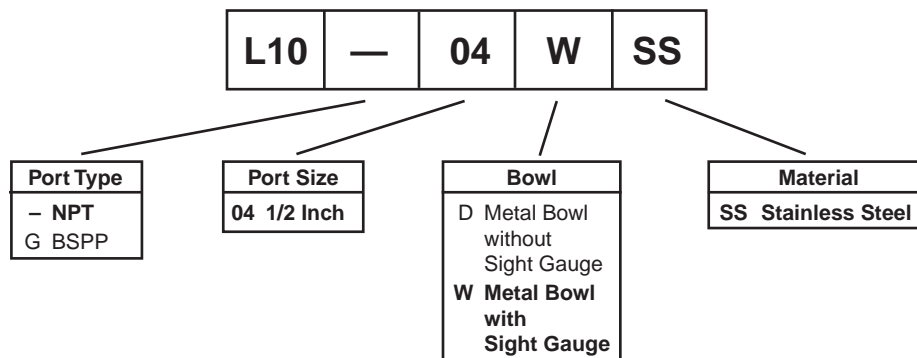

**BOLD ITEMS ARE MOST POPULAR.**

**Technical Specifications – L10**

**Operation**

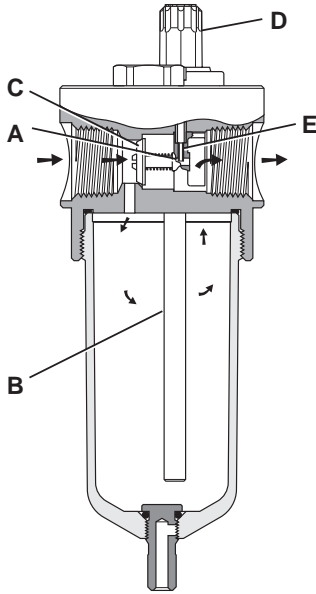

Air flowing through the unit goes through two paths. At low flow rates the majority of the air flows through the Venturi section (A). The rest of the air opens the check valve (C). The velocity of the air flowing through the Venturi section (A) creates a pressure drop. This lower pressure allows the oil to be forced from the reservoir through the pickup tube (B) and travels up to the metering screw (D). The rate of oil delivery is then controlled by adjusting the metering screw (D). Oil flows past the metering screw (D) and forms a drop in the nozzle tube (E). As the oil drops through the dome (F) and back into the Venturi section (A), it is broken up into fine particles. It is then mixed with the air flowing past the check valve (C) and is carried downstream. As the air flow increases the check valve (C) will open more fully. This additional flow will assure that the oil delivery rate will increase linearly with the increase of air flow.

**Technical Information**

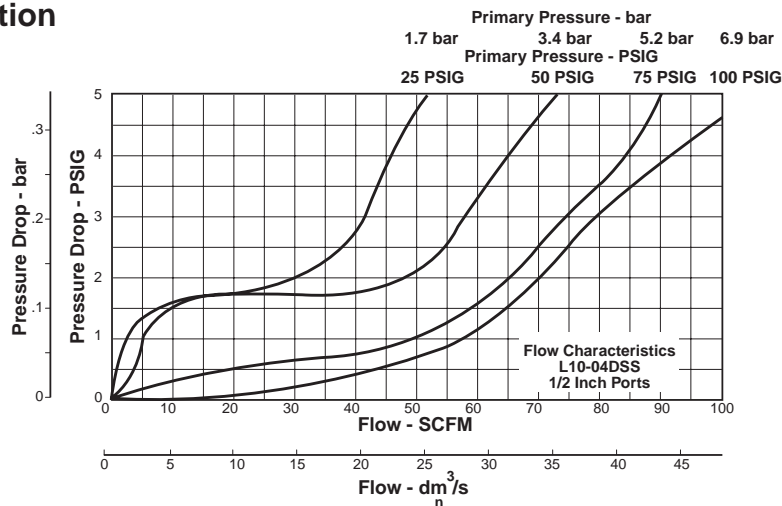

**L10 Filter Kits & Accessories**

- Drain Kit –
  - Manual Twist Drain ..... SA600Y7-1SS
- Pipe Nipple –
  - 1/2" 316 Stainless Steel ..... 616A28-SS
- Sight Dome Kit ..... RKL10SS

**Specifications**

- Bowl Capacity ..... 4.0 Ounces
- Port Threads ..... 1/2 Inch
- Pressure & Temperature Ratings –
  - Metal Bowl (D) ..... 300 PSIG Max (20.7 bar)  
0°F to 180°F (-18°C to 82°C) Auto Drain Ratings
  - Metal Bowl (W) ..... 0 to 250 PSIG (0 to 17.2 bar)  
0°F to 180°F (-18°C to 82°C)

**Note: Air must be dry enough to avoid ice formation at temperatures below 32°F (0°C).**

Weight ..... 1.9 lb. (0.85 kg)

**Materials of Construction**

- Body ..... 316 Stainless Steel
- Bowl ..... 316 Stainless Steel
- Dip Tube ..... 316 Stainless Steel
- Drain ..... 316 Stainless Steel
- Fill Plug ..... 316 Stainless Steel
- Seals ..... Fluorocarbon
- Sight Dome ..... Nylon
- Sight Gauge ..... Isoplast



**Notes**

---

**Notes**

**D**