

Section E



E

Introduction		PL50 Multi-Point Injection Lubricators	
Why Injection Lubrication?	E2	Features, Ordering Information	E8
Which Kind of Injection Lubricator Do I Need?.....	E3	Technical Information	E9
Injection Lubricators		Typical Air Drop Application	E10
In-Line Features	E4	Accessories	E11
Multi-Point Features	E5		
L50 In-Line Injection Lubricators			
Features, Ordering Information	E6		
Technical Information	E7		

Why Injection Lubrication?

In many cases, conventional air line lubricators cannot supply adequate lubrication to tools, cylinders, etc. This is due to many factors such as long distances between tool and lubricator, intermittent flow, and complex piping. Parker/Watts Injection Lubricators are

designed to deliver precise amounts of oil directly to the point of lubrication as required. To ensure proper lubrication, our injection lubrication products and accessories are available to cover a wide range of applications.

How It Works...

Oil Injection Module

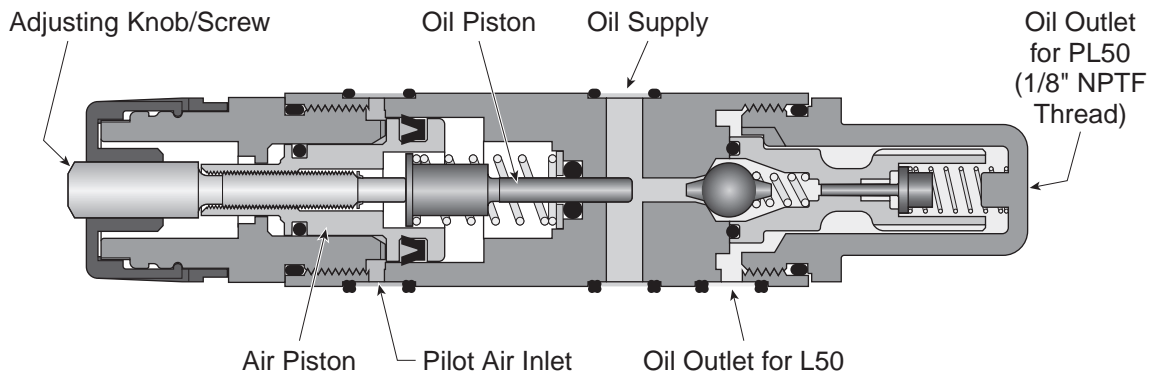

When the pneumatic circuit is energized:

- 1.) Air pressure is routed to the air piston
- 2.) The air piston pushes on the oil piston
- 3.) The oil piston enters the oil cylinder bore and forces an exact amount of oil past the check valve to the outlet.
- 4.) The adjusting knob/screw is used to control the oil piston travel, effectively controlling the amount of oil delivered per actuation.

E

Oil Delivery

Single Point – L50

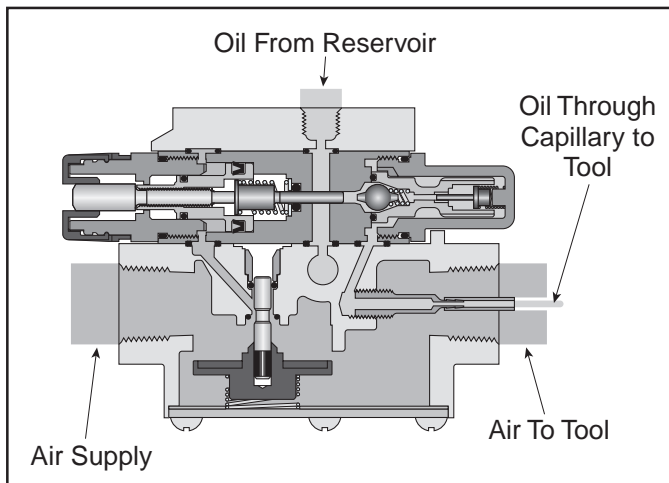

Single/Multi Point – PL50

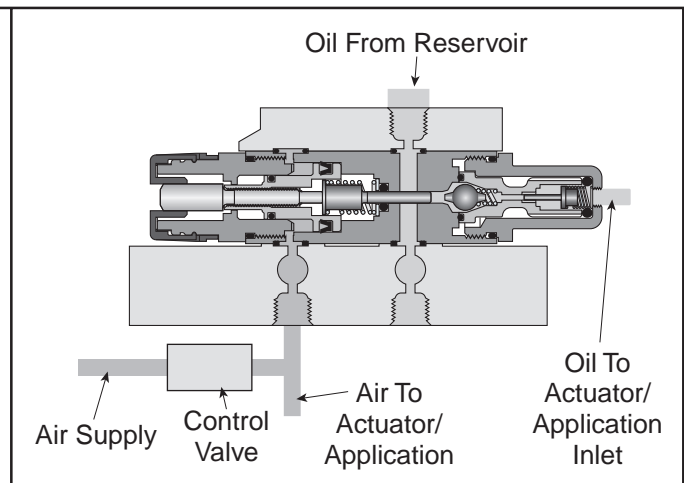

Which Kind of Injection Lubricator Do I Need?

Selecting a Lubricator

Common Applications	Lubricator Type	Number of Lubrication Points	Air Consumption	Cycle Operating Time	Cycle Counter	Pulse Generator
Air Tool - Hand Held	L50	One	1 - 40 SCFM	1-30 Seconds	Recommended	No
	L50	One	20 - 40 SCFM	1-30 Seconds	Not Necessary	No
	L50	One	10 - 50 SCFM	30 Seconds +	No	Recommended
Air Motor - Fixed Mount	PL50	One or Many ¹	1 - 40 SCFM	1-30 Seconds	Recommended	No
	PL50	One or Many ¹	20 - 40 SCFM	1-30 Seconds	Not Necessary	No
	PL50	One or Many ¹	10 - 50 SCFM	30 Seconds +	No	Recommended
Cylinder/Actuator	PL50	One or Many ¹	1 - 40 SCFM	1-30 Seconds	Recommended	No
	PL50	One or Many ¹	20 - 40 SCFM	1-30 Seconds	Not Necessary	No
	PL50	One or Many ¹	10 - 50 SCFM	30 Seconds +	No	Recommended

Note: If multiple points are to be lubricated in unison, use a Single Lubricator - Multiple Modules
If multiple points are to be lubricated at different times, use Multiple Lubricators - Single or Multiple Modules

Options – Oil Delivery

Cycle Counter Option

For both L50 & PL50



All pneumatic device designed for applications where the **minimum** amount of oil injected every cycle is **too much**. The cycle counter controls oil delivery by reducing oil injection from every air cycle, to every 5th or 10th air cycle. The cycle counter also has settings allowing the module to operate with every air cycle, or turn off to stop injector module operation.
(Maximum of 3 modules above counter on PL50)

Common Applications:

- Minimal oil demands
- Short cycle times
- Small tools
- Small cylinders

Pulse Generator Option

For both L50 & PL50

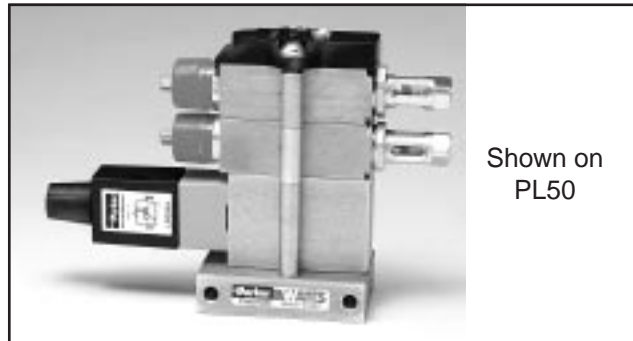

All pneumatic device designed for applications where the **maximum** amount of oil injected every cycle is **not enough**. The pulse generator increases oil delivery by generating oil injector cycles, effectively increasing oil delivery for long tool/application cycles.
(Maximum of 10 modules above generator on PL50)

Common Applications:

- Long cycle times
(L50: air motor/tool)
- Consistent lubrication intervals
(PL50: chain/slide lubrication)

In-Line Injection Lubricators



L50 Single Point Injection Lubricator

The L50 Injection Lubricator is an in-line unit for use with tools and other pneumatic equipment which require consistent lubrication for longer life and maximum torque control. These units, available in 1/2" and 3/4" NPT, deliver an adjustable amount of oil through a capillary tube inside the main airline, directly to the tool. The amount of oil is adjustable up to .03cc. These units are designed for intermittent operation. Each time the tool is cycled, the unit injects the oil through the capillary tube to the lubrication point.

If the minimum amount of oil is injected per cycle is too much, than the cycle counter may be added. Or, conversely, if the amount of oil injected per cycle is not enough due to long cycle times, a pulse generator is available.

Operation:

Every time air flow starts, the sensor piston (1) is pushed down and allows a pilot pressure to flow through port (2) which drives module piston (3) and metering plunger (4) to the right. As plunger passes by oil supply port (5), it forces oil into metering tube (6) which in turn lifts check valve (7) and forces the same quantity of oil into inner sight glass, it drives flow indicator (8) to the right (a positive indication of oil flow) and then flows up through annular area between inner and outer sight glass (9). It next flows down through out port (10) and capillary adapter (11) to capillary (12) adapted for internal feed. When air flow stops, the sensor piston is returned by its spring to the initial no-flow position and the pilot pressure behind metering piston is exhausted to atmosphere through exhaust valve (13) and exhaust port. When air is exhausted metering piston spring returns piston and plunger to initial position. As can be seen by referring to Figure A, the amount of oil injected into the system is determined by the distance the metering plunger (4) travels into the metering tube (6). The distance it travels to the right (into the tube) determines the quantity of oil that is forced out through the check valve (7) and into the system. Since the module piston always travels a set distance from point (A) to (B), oil feed rate is adjusted by varying the protruded length of the metering plunger. The longer the plunger, the greater the travel and the greater the oil feed per cycle. An adjusting knob (14) is provided to adjust the plunger length.

To operate, the knob must first be pulled into the unlocked position. Then as the knob is turned in a clockwise direction the adjusting screw (15) moves to the right and extends the metering plunger (4). Since the module/air piston (3) remains stationary, the extended length of the metering plunger is increased. Therefore, the next time the module is fired (pressurized), the metering plunger will travel a longer distance into the metering tube (6) so more oil will be forced through check valve and into system. Conversely, counter-clockwise rotation of the adjustment knob (14) will shorten the extended length of the plunger and decrease the amount of oil feed.

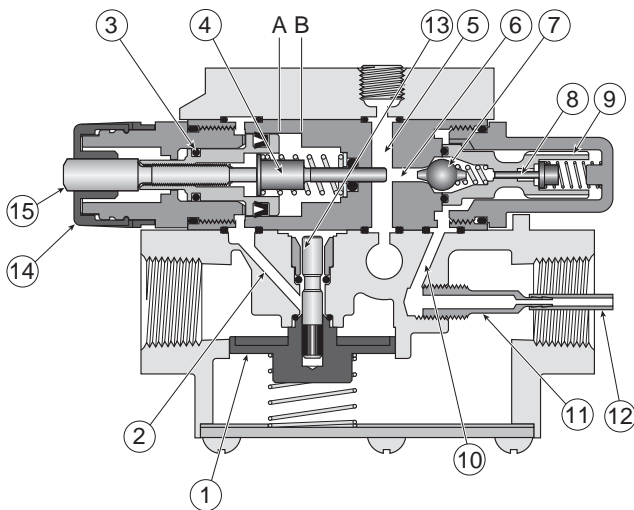

(Shown Without Cycle Counter)

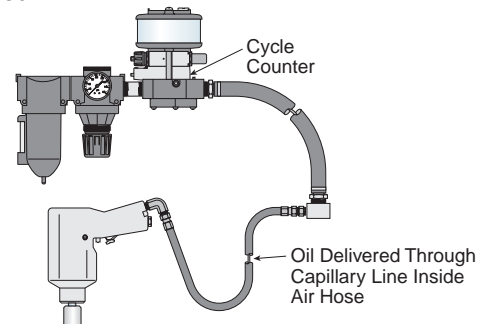

E

Multi-Point Injection Lubricators



PL50 Multi-Point Injection Lubricator

The PL50 Injection Lubricator is designed to lubricate from one to ten points when sensing a single remote pilot signal. Like the L50, precise amounts of oil are injected directly at each of the lubrication points. Unlike the L50, a single air pilot signal fires the injector modules in the stack, and the oil is delivered by an external capillary tube directly to the air inlet of the point to be lubricated. The PL50 is ideal for multi-spindle air tools, automation equipment, air cylinders, and other components with intermittent operation which are difficult to lubricate.

If the minimum amount of oil is injected per cycle is too much, than the cycle counter may be added. Or, conversely, if the amount of oil injected per cycle is not enough due to long cycle times, a pulse generator is available.

A note about lubricating multiple points:

- How many points do you need to lubricate?
- How many lubricators do you need?

The PL50 Injection Lubricator will lubricate from 1 to 10 points all at one time. If your application has 6 cylinders to lubricate, and all 6 cylinders cycle at the same time, then the application requires one lubricator with 6 modules. If your application has 6 cylinders to lubricate, and 3 cylinders operate in one cycle, and the remaining 3 operate on a different cycle, then the application will require two 3 module lubricators.

Single Signal

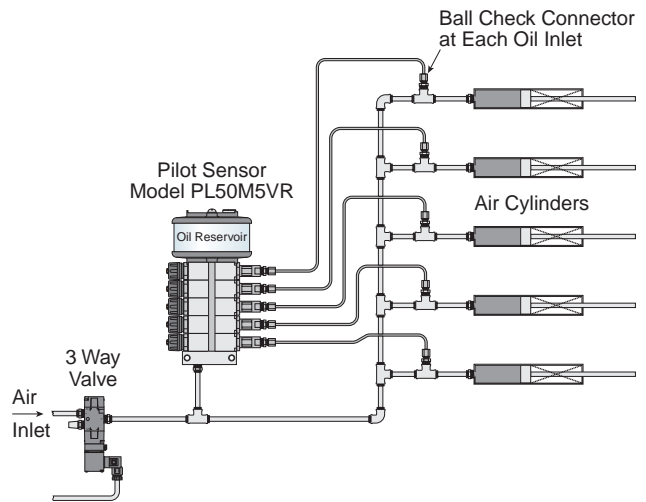

Two Separate Signals

Oil is Dispensed as Cylinder Extends

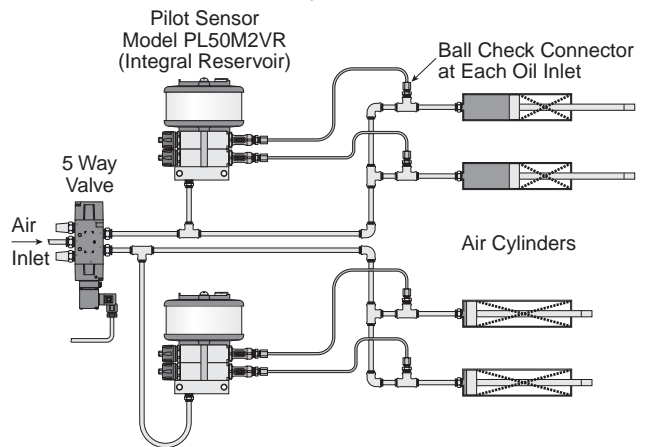

Direct Application Configuration

PL50 Application (with Pulse Generator)

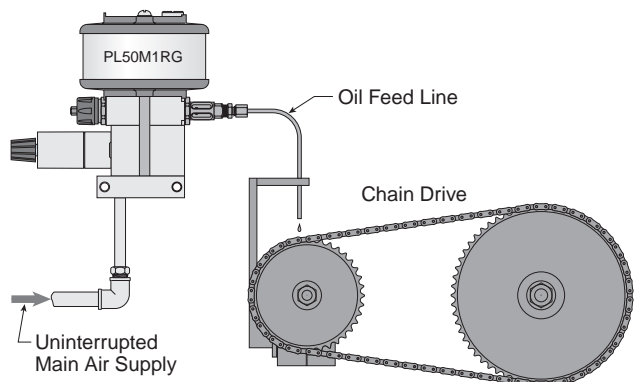

L50 In-Line Injection Lubricators



Dependable Oil Delivery

L50 In-Line Injection Lubricators provide positive oil displacement lubrication ensuring the predetermined amount of oil is delivered to the tool each and every cycle regardless of pressure or flow.

For best results unit must be used with capillary line inside air outlet or with coaxial tool hoses (see accessories).

Features:

- **Air Flow Sensor**
Single point injection lubricators are installed between a filtered, regulated air source and an air supply hose going to a pneumatic tool. The body of the unit is designed to sense air flow when the tool is being used and signal the oil injector module to lubricate.
- **Oil Injector Module**
The oil injector module provides adjustable oil delivery in amounts up to 1 drop per cycle. Oil delivery adjustment is made by turning the adjusting knob increasing or decreasing the oil piston travel in the module. Unit comes standard with oil delivery indicator.
- **Cycle Counter - 4 Position - Optional**
With the adjustable cycle counter, the lubricator can be set to dispense oil in the following manner:
Setting: Off No oil dispensed
 1 Every cycle of the application
 5 Every fifth cycle of the application
 10 Every tenth cycle of the application
- **Pulse Generator - Optional**
For long cycle time applications the pulse generator makes the lubricator dispense a pre-determined amount of oil multiple times during a single tool cycle.

Ordering Information

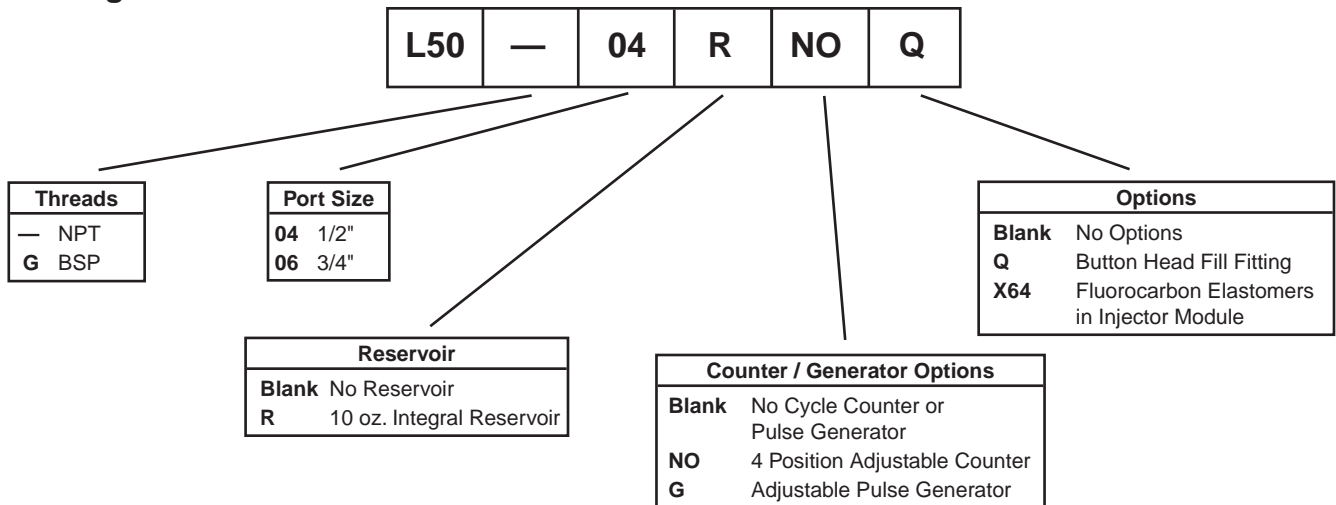

E

Dimensions

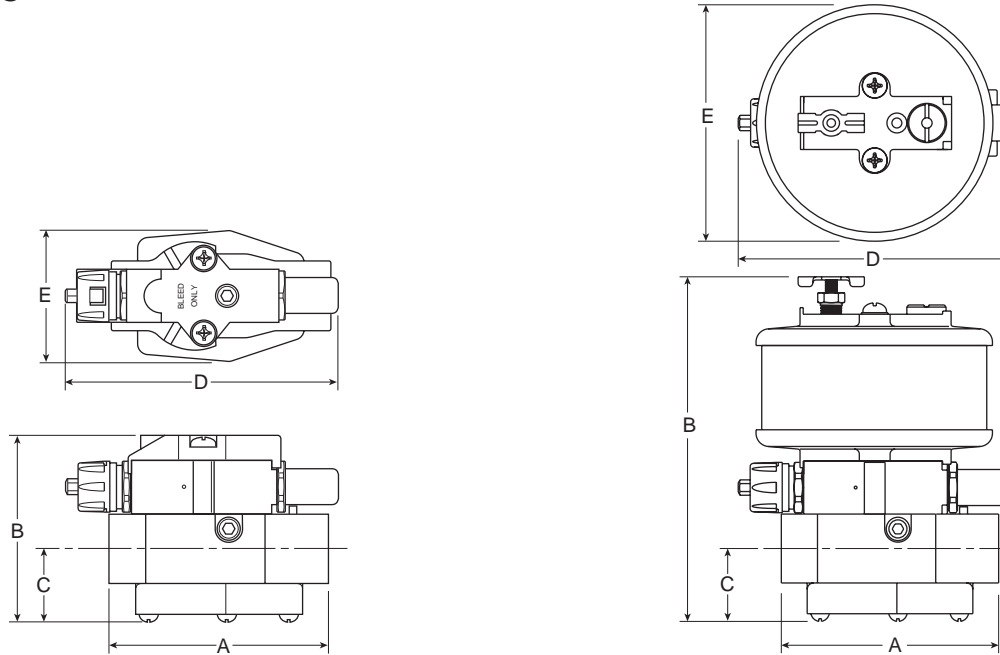

Amount Of Oil Injected Per Machine (Tool) Cycle With Cycle Counter

Injector Module Setting	Clicks Counter-clockwise	Turns Counter-clockwise	Cycle Counter Setting			
			Off	1 (or w/o Counter)	5	10
			Prime			
0	0	▶	0			
8	1	▶	0			
16	2	▶	0	0.024 cc	0.005 cc	0.002 cc
24	3	▶	0	0.018 cc	0.003 cc	0.002 cc
32	4	▶	0	0.012 cc	0.002 cc	0.001 cc
40	5	▶	0	0.006 cc	0.001 cc	—
48	6	▶	0	—	—	—

L50 Dimensions

	A	B	C	D	E
Standard Unit	4.13 (104.8)	3.48 (88.4)	1.38 (35)	5.09 (129.3)	2.44 (61.9)
For Integral Reservoir Add:	—	3.0 (76.2)	—	—	2.01 (51)
For Cycle Counter Add:	—	0.88 (22.4)	—	—	—
For Pulse Generator Add:	—	1.75 (44.5)	—	2.06 (52.3)	—

inches (mm)

Repair Kits & Accessories

- Injector Module
 - Sight Dome End Repair KitRKL50SD
 - Adjustment End Only RKL50MA
 - Module Kit KL50M
- Sensor Body
 - Sensor PistonSAL50-0472
- Button Head Fill FittingSA606Y107
- Integral 10 oz. Reservoir BKL50R
- Cycle Counter Kit RKL50NO
- Pulse Generator KitRKL50G

Specifications

- Maximum Air Supply Pressure 150 PSIG
- Oil Supply Pressure Range Gravity Feed to 20 PSIG Max.
- Oil Viscosity Range 150-1200 S.S.U.
- Minimum Airflow for Operation5 SCFM
- Oil Delivery Range0-1 Drop per Cycle of Injector
- Pressure DropLess than 5 PSIG @ 100 SCFM
- Oil Fill Port 1/8" NPT

Materials of Construction

- Injector Module
 - BodyAluminum
 - Oil Piston Steel
 - Air Piston Ultem
 - Sight Dome Polyurethane
 - Springs Steel
 - End Plug Brass
 - Seals Buna-N (Fluorocarbon Optional)
- Flow Sensor Body
 - BodyZinc
 - Bottom Plate Steel
 - Sensor Piston Aluminum / Brass
 - Spring Steel
 - Top PlateZinc
- Reservoir
 - Top & Bottom PlateZinc
 - Reservoir CylinderPolycarbonate
 - Seals Buna-N
- Cycle Counter
 - Body Nylon
 - Seals Buna-N
- Pulse Generator
 - BodyAluminum
 - Timer Acetal / Steel / Buna-N



PL50 Multi-Point Injection Lubricators

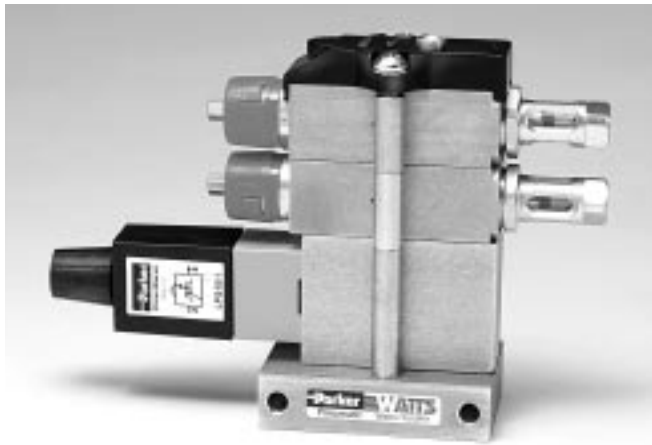

Individual Points of Lubrication

PL50 Multi-Point Injection Lubricators use an air pilot signal to provide positive displacement lubrication to either single or multiple points ensuring the predetermined amount of oil is delivered to each point per cycle regardless of pressure or flow.

The PL50 delivers oil externally to the air inlet to a pneumatic device where it is “tee’d” into the air line.

Features:

- **Oil Injector Module**

The oil injector module provides adjustable oil delivery in amounts up to 1 drop per cycle. Oil delivery adjustment is made by turning the adjusting knob increasing or decreasing the oil piston travel in the module. Optional visible oil delivery indicator(s) are available - and recommended - ensure visual proof of lubrication at each point.

- **Cycle Counter - 4 Position - Optional**

With the adjustable cycle counter, the lubricator can be set to dispense oil in the following manner:
 (Maximum of 3 modules above cycle counter)

- Setting: Off No oil dispensed
- 1 Every cycle of the application
 - 5 Every fifth cycle of the application
 - 10 Every tenth cycle of the application

- **Pulse Generator - Optional**

For long cycle time applications the pulse generator makes the lubricator dispense a pre-determined amount of oil multiple times during a single tool cycle.

(Maximum of 10 modules above pulse generator)

Ordering Information

PL50M 2 V R NO Q

Number of Modules	
1	1 Module
2	2 Modules
10	Modules Maximum

Oil Outlet Connection	
Blank	1/8" NPT w/o Visible Indicator
V	1/8" NPT w/ Visible Indicator

Reservoir	
Blank	No Reservoir
R	10 oz. Integral Reservoir

Counter / Generator Options	
Blank	No Cycle Counter or Pulse Generator
NO	4 Position Adjustable Counter (Maximum of 3 modules above cycle counter)
G	Adjustable Pulse Generator

Position of Cycle Counter or Pulse Generator	
(Indicates # of modules below counter or generator)	
Blank	Standard Configuration (Counter or Generator operates all modules)
1	1 module below counter
2	2 modules below counter
...etc.	...etc.

Options	
Blank	No Options
Q	Button Head Fill Fitting
X64	Fluorocarbon Elastomers in Injector Module

E

Dimensions

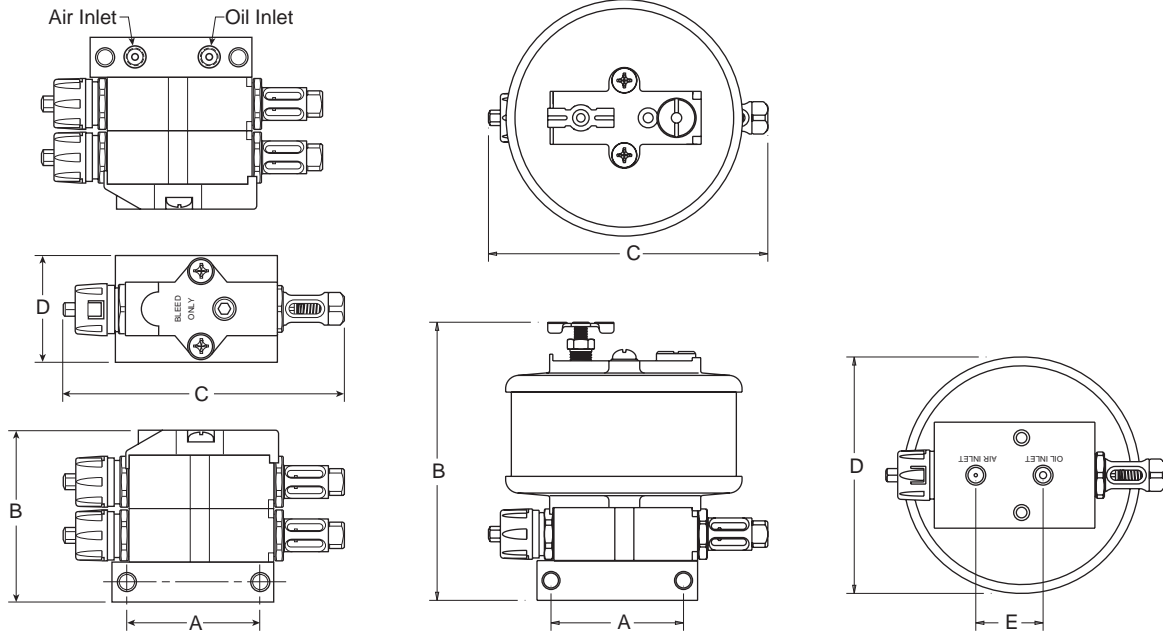

Amount Of Oil Injected Per Machine (Tool) Cycle With Cycle Counter

Injector Module Setting	Clicks Counter-clockwise	Turns Counter-clockwise	Cycle Counter Setting			
			Off	1	5	10
				(or w/o Counter)		
0	0	▶	0	Prime		
8	1	▶	0	Prime		
16	2	▶	0	0.024 cc	0.005 cc	0.002 cc
24	3	▶	0	0.018 cc	0.003 cc	0.002 cc
32	4	▶	0	0.012 cc	0.002 cc	0.001 cc
40	5	▶	0	0.006 cc	0.001 cc	—
48	6	▶	0	—	—	—

PL50 Dimensions

	A	B	C	D	E
Standard 1 Module Unit w/o Visible Indicator	2.50 (63.5)	2.48 (63)	5.27 (133.9)	2.00 (51)	1.27 (32.3)
For Each Additional Module Add:	—	1 (25.4)	—	—	—
For Visible Indicators Add:	—	—	0.85 (21.6)	—	—
For Integral Reservoir Add:	—	3.0 (76.2)	—	2.46 (62.5)	—
For Cycle Counter Add:	—	0.88 (22.4)	—	—	—
For Pulse Generator Add:	—	1.75 (44.5)	2.06 (52.3)	—	—

inches (mm)

Repair Kits & Accessories

- Injector Module
 - Visible Indicator End Repair KitRKL50MD
 - Adjustment End OnlyRKL50MA
 - Module Kit - Visible IndicatorKPL50MV
 - Module Kit - Non-Visible IndicatorKPL50M
- Button Head Fill FittingSA606Y107
- Integral 10 oz. ReservoirBKL50R
- Cycle Counter KitRKL50NO
- Pulse Generator KitRKL50G

Specifications

- Maximum Air Supply Pressure 150 PSIG
- Oil Supply Pressure Range Gravity Feed to 20 PSIG Max.
- Oil Viscosity Range 150-1200 S.S.U.
- Minimum Airflow for Operation 5 SCFM
- Oil Delivery Range 0-1 Drop per Cycle of Injector
- Pressure Drop Less than 5 PSIG @ 100 SCFM
- Oil Fill Port 1/8" NPT
- Air Signal Pilot Port 1/8" NPT

Materials of Construction

- Injector Module
 - BodyAluminum
 - Oil Piston Steel
 - Air Piston Ultem
 - Sight Dome Polyurethane
 - Springs Steel
 - End Plug Brass
 - Seals Buna-N (Fluorocarbon Optional)
- Bottom PlateAluminum
- Top PlateZinc
- Reservoir
 - Top & Bottom PlateZinc
 - Reservoir CylinderPolycarbonate
 - Seals Buna-N
- Cycle Counter
 - Body Nylon
 - Seals Buna-N
- Pulse Generator
 - BodyAluminum
 - Timer Acetal / Steel / Buna-N



Typical Air Drop Application

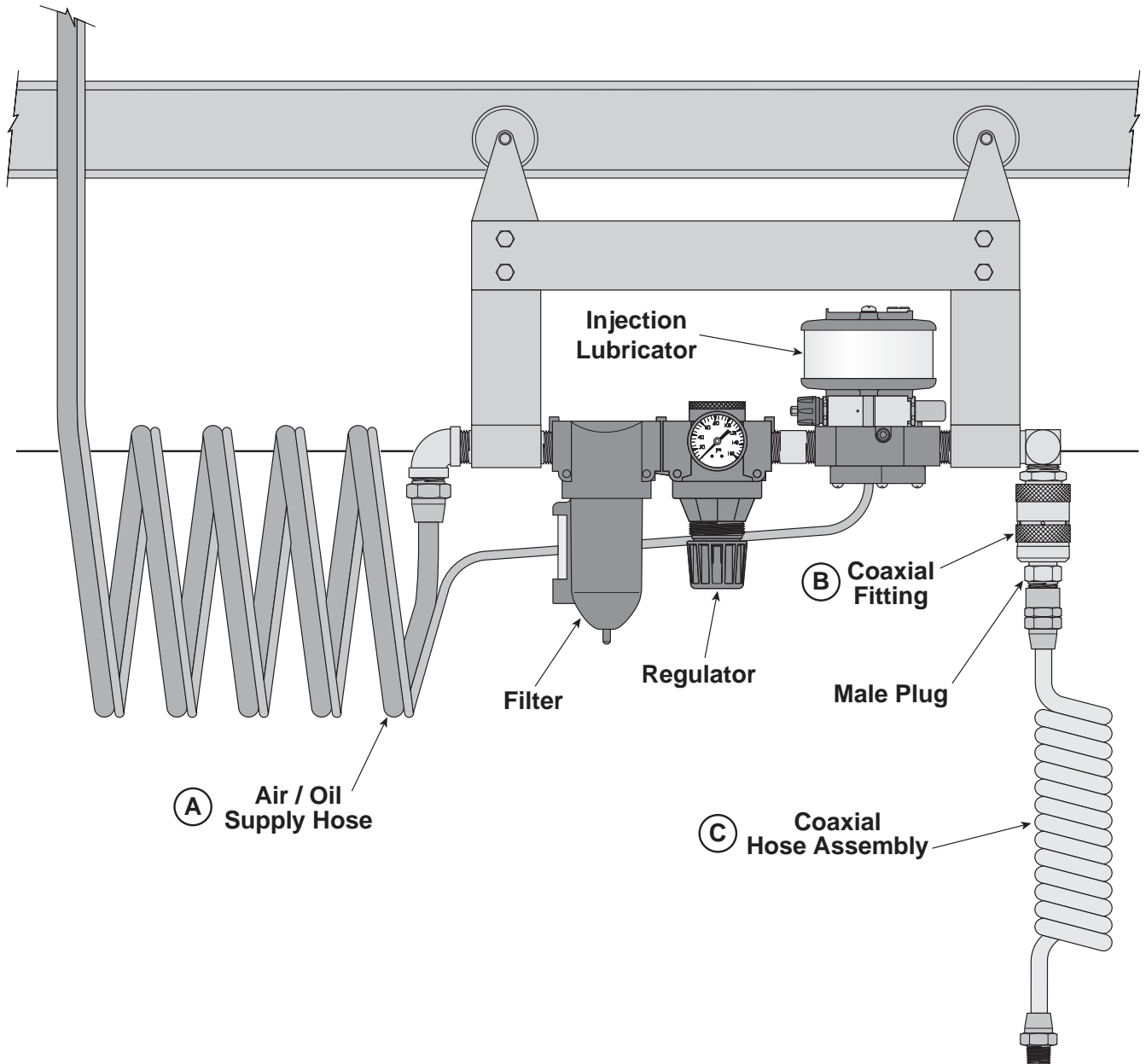

E

Accessories

Oil Reservoirs

(All units come with mounting bracket)

BKL50A

9 oz. polycarbonate bowl

Diameter 2.87 (73)
 Overall Height 5.5 (140)
 Mount to Top 4.87 (124)
 Mount to Bottom..... .63 (16)



BKL50B

1 qt. polycarbonate bowl

Diameter 4.25 (108)
 Overall Height 7.44 (189)
 Mount to Top 6.81 (167)
 Mount to Bottom..... .63 (16)



BKL50C

2 qt. polycarbonate bowl

Diameter 5.5 (140)
 Overall Height 9.44 (247)
 Mount to Top 8.81 (224)
 Mount to Bottom..... .63 (16)



inches (mm)

Button Head Fill Fitting

SA606Y107

1/8" NPT Male



Oil filled Capillary Line

SA606X71-1 25 Feet

SA606Y71-1 50 Feet



Capillary Line Connectors

SAL50Y139

1/8" OD compression X
 1/8" NPT male connector



SA606Z26

1/8" OD compression X
 1/8" NPT male check valve



Supply and Tool Hoses & Fittings

(A) Air / Oil Supply Hose

ASH-25

Air Supply Hose - 25 Feet
 3/4" male NPT swivel fittings



AOSH-25

Air & Oil Supply Hose - 25 Feet
 3/4" male NPT swivel fittings



(B) Coaxial Fittings

CES-06

Coaxial Elbow & Socket
 Inlet: 3/4" male NPT
 Outlet: 3/4" female coax socket



CDS-06

Coaxial Direct Socket
 Inlet: 3/4" male NPT
 Outlet: 3/4" female coax socket



(C) Coaxial Hose Assemblies

THC-20

Coiled Tool Hose - 20 Feet
 Tube Dia: 3/8"
 Inlet: 3/4" male coax plug
 Outlet: 3/8" male NPT



THS-20

Straight Tool Hose - 20 Feet
 Tube Dia: 3/8"
 Inlet: 3/4" male coax plug
 Outlet: 3/8" male NPT



DW-06-2

Drop-Whip Hose - 2 Feet
 Inlet: 3/4" male NPT
 Outlet: 3/4" female coax socket



E

Notes

E